



IMechE Simulation Conference 2023

“New perspectives on interoperability across design simulation and validation in an integrated design process”

*Professor Mark Price
Mechanical and Aerospace Engineering
Queen’s University Belfast*



Contents

- Re-Imagining Engineering Design
 - Overview in numbers, scale & partners
- Challenges in Design
 - Linear, siloed, data, total processes
- New ways of thinking...inspiration from nature
- Practical Example
- Integration & Interoperability



Engineering and Physical Sciences Research Council



Re-Imagining Engineering Design NI Manufacturing and Supply Chain Expo 2023



Mark Price
Trevor Robinson
Frank Kirkland
Yan Jin
Karen Rafferty
Declan Nolan
Peter Kilpatrick
Imelda Friel
Andrew Colligan
Andrew Mowles
Dearbhla Magill
Daniel Brice
Zhiwei Zhao

Andy Tyrrell
Simon Hickinbotham
Rahul Dubey
Edgar Buchanan Berumen



Plus PhD Students
Jonathan Brady (QUB)
Julian Francis (QUB)
Thomas Whittaker (QUB)
Orlagh Casey (QUB)



Paul Conway
Paul Goodall
Carmen Torres-Sanchez
Andrew West
Radmehr Monfared
Abdur Siddiq

Shangmou Yang (Loughborough)
Mudassar Khalil (Loughborough)

Colin Roitt (York)



Independent ICF Advisor -



In numbers...

- Total Project Value is ~£11M (Full Cost) to run for 5 years.
- 12 Academics from 3 Institutions: QUB, York, Loughborough.
- Company partners include Airbus, Glen Dimplex, ITI, Rolls-Royce, Denroy, SAM UK, MTC, Far UK, OxMet, Bombardier
- EPSRC Grant of £7.2M
- Total Industrial Partner support to value of £1.5M
- 10+ PDRA across the three sites.
- Academic & Industrial support brings 14 PhD studentships



In Geographical spread...

- Partnership drawn from across UK.
- Team Size currently:
 - 12 Academic Staff
 - 9 Post Doctoral Researchers
 - 7 PhDs
 - 7 more joining/advertised currently
- Partnering with AMIC to speed up the transition of tools & process into practice.
- *Join AMIC & get in early!!*

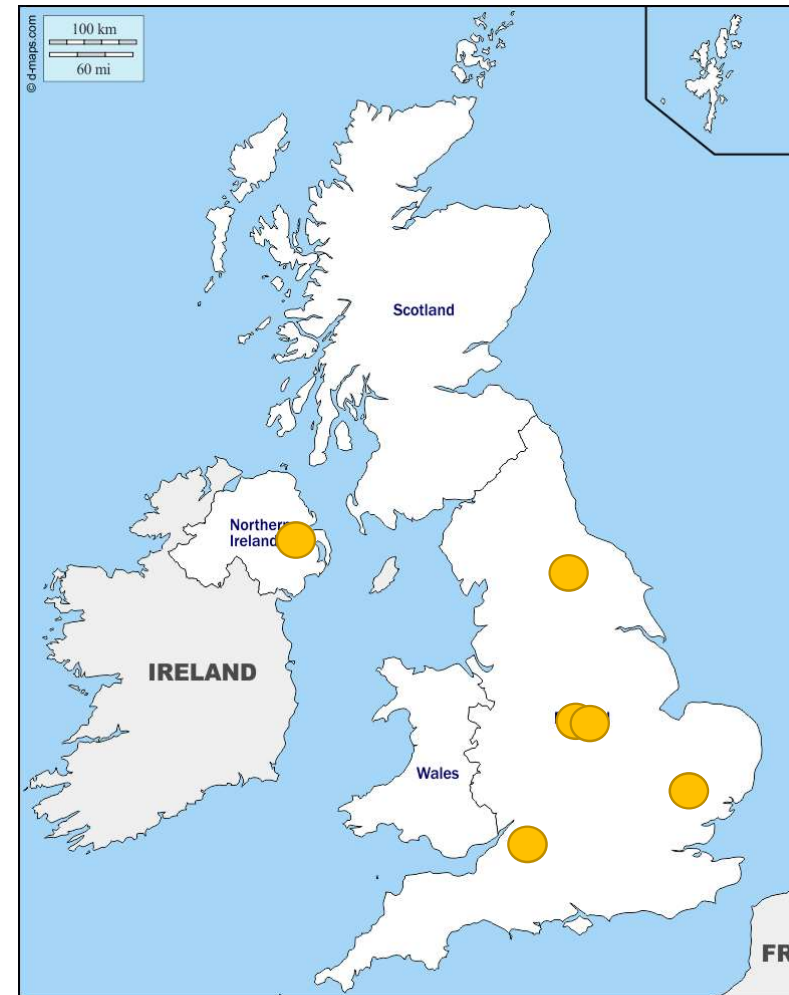



**ADVANCED
MANUFACTURING
INNOVATION
CENTRE**

**AMIC SMART DESIGN
&
RIED**

MANUFACTURING
INNOVATION
FOR REAL
WORLD IMPACT

AMIC Contact: Professor Sam Turner CEO s.turner@qub.ac.uk



QUEEN'S
UNIVERSITY
BELFAST



BELFAST
REGION
CITY DEAL



Challenges in Design for Manufacture



Weight versus Waste versus Costs versus Demand

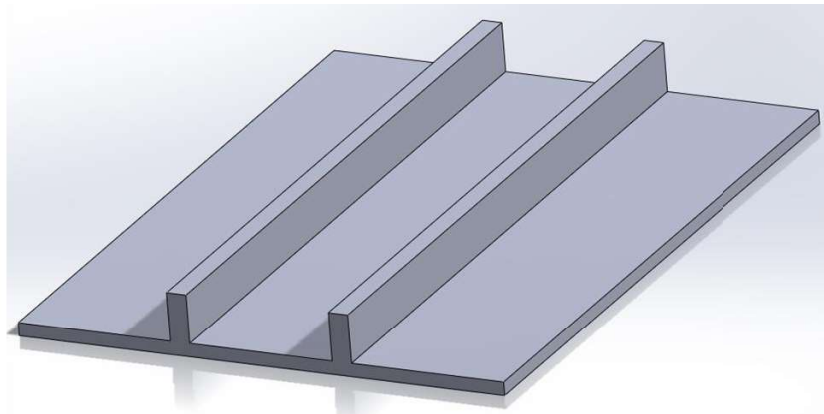

Product Material Input (PMI) = Product + Waste (W)

Machined from block

$$PMI_1 = L_1 \times D_4$$

$$W = (D_1 \times L_2) + (L_3 \times D_2) + (L_4 \times D_3)$$

Weld option 1

$$PMI_2 = (L_1 + D_1 + D_2) \times \text{Max}(D_3, L_2, L_3)$$

$$W = [(\text{Max}(D_3, L_2, L_3) - \text{Min}(D_3, L_2, L_3)) \times \text{Length}(\text{Min})] + [(\text{Max}(D_3, L_2, L_3) - \text{Median}(D_3, L_2, L_3)) \times \text{Length}(\text{Median})]$$

Weld option 2

If designed such that $D_3 = L_2 = L_3$

$$PMI_3 = (L_1 + D_1 + D_2) \times D_3$$

$$W = 0$$

Machined from block

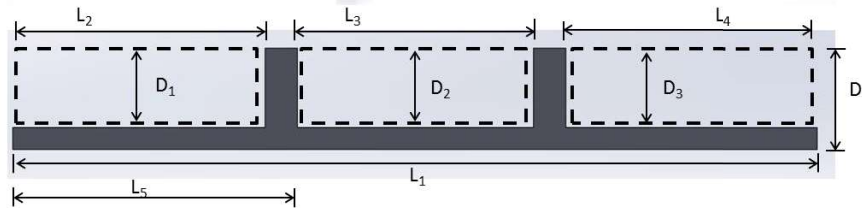

Weld

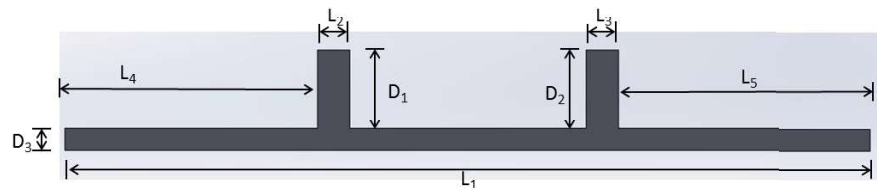

We cannot assume
 $PMI_1 > PMI_2 > PMI_3$

The Design Process should distinguish between these for the designer/maker!

Re-Imagining Engineering Design

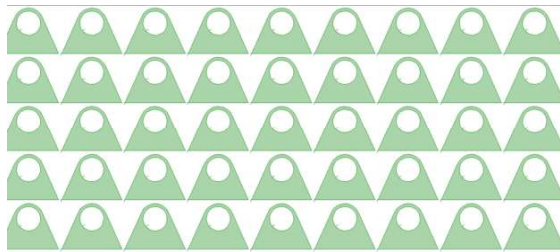

Alternative nesting solution

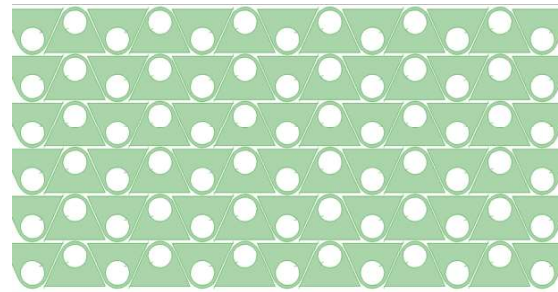

Playing with thickness can allow for larger bolts for example, and alternative nesting & stacking options.

There is a trade-off between material needed for the task, material lost in production process, and life of the product.

Minimal waste \neq Minimal Material \neq Minimal Demand!

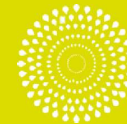

Ontology map – mind blowing!

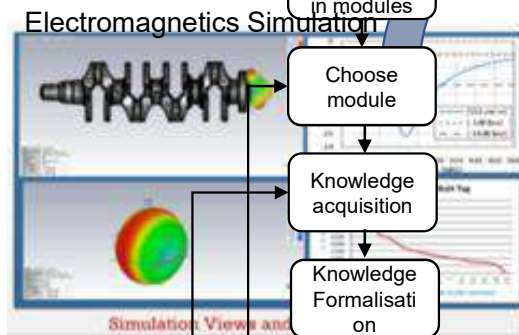
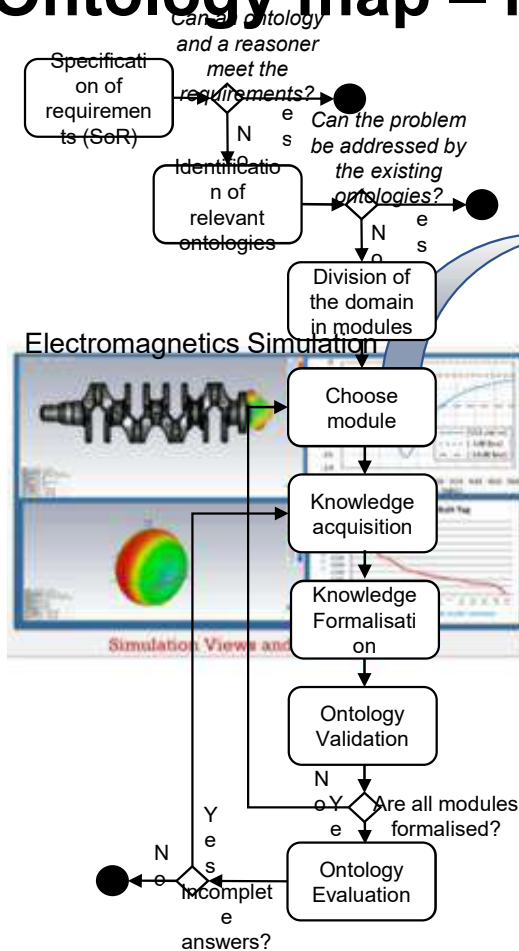

CPS-P Knowledge Interoperability

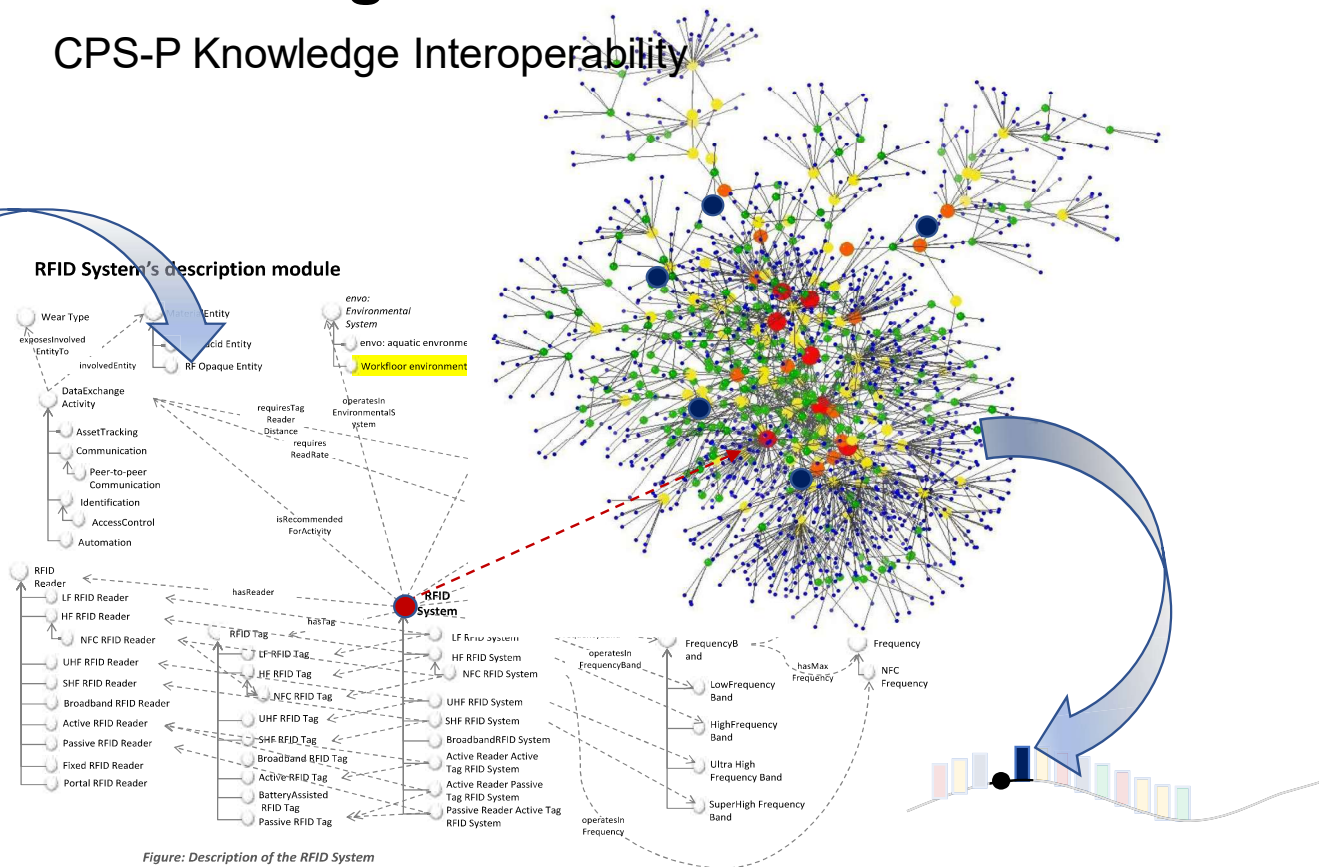
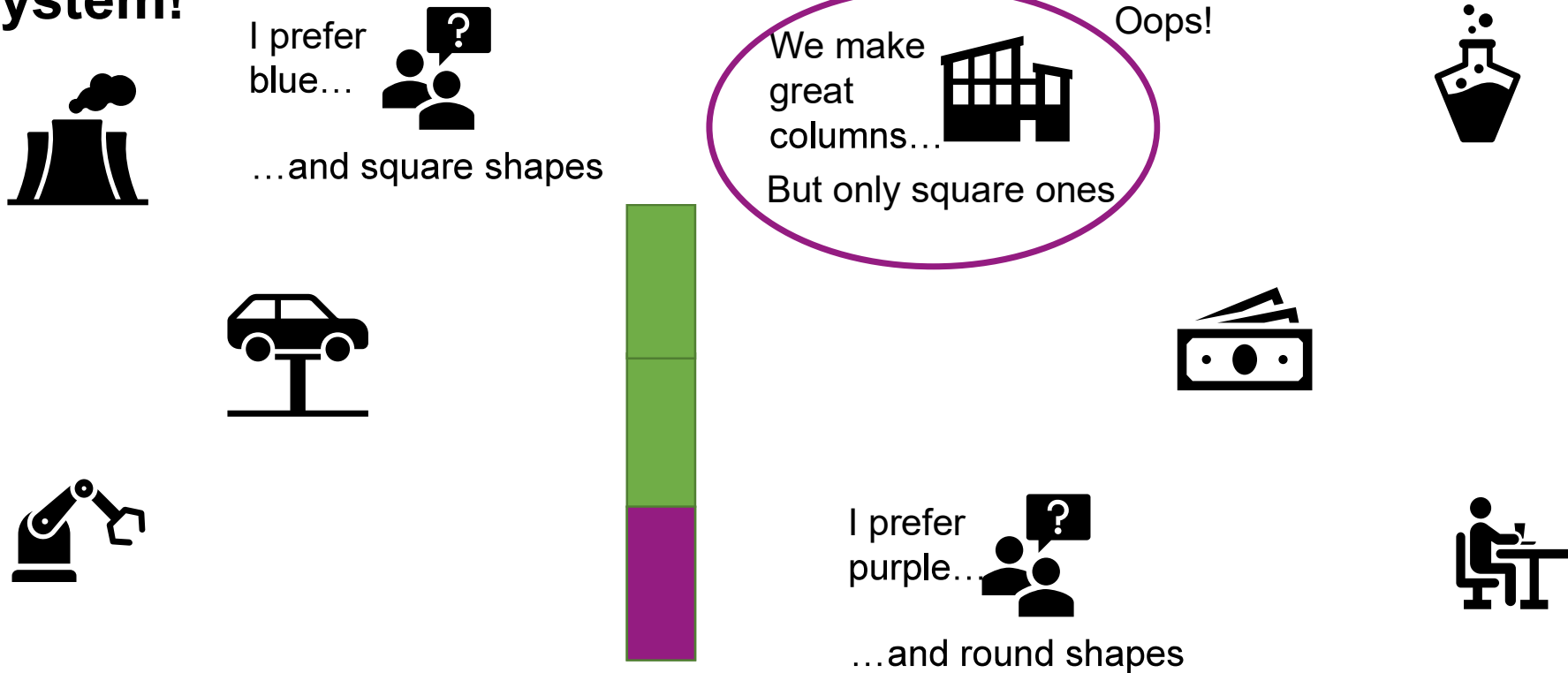

Figure: Description of the RFID System



It gets even more complicated when we think of the wider system!



Objectives are often conflicting

Re-Imagining Engineering Design



The process is very, very complex...

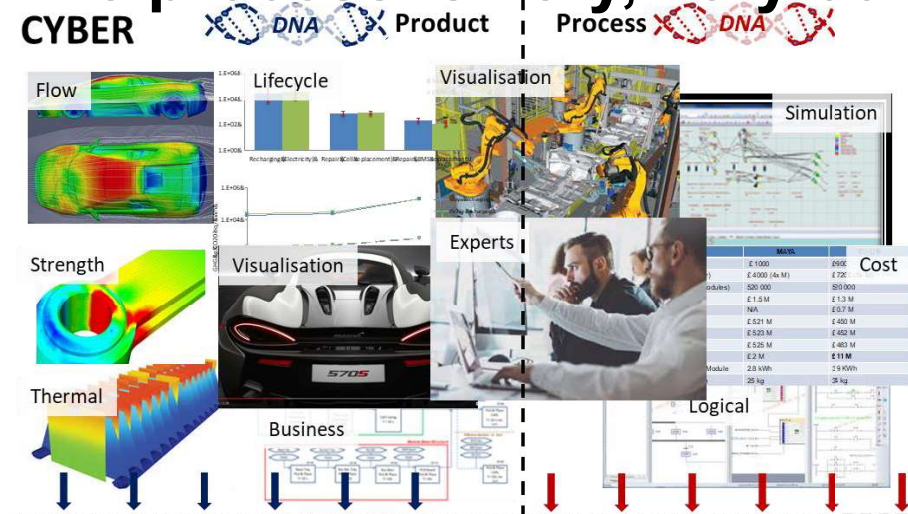

Cyber Physical Social Systems (CPSS): Interoperable CONCEPT BUS

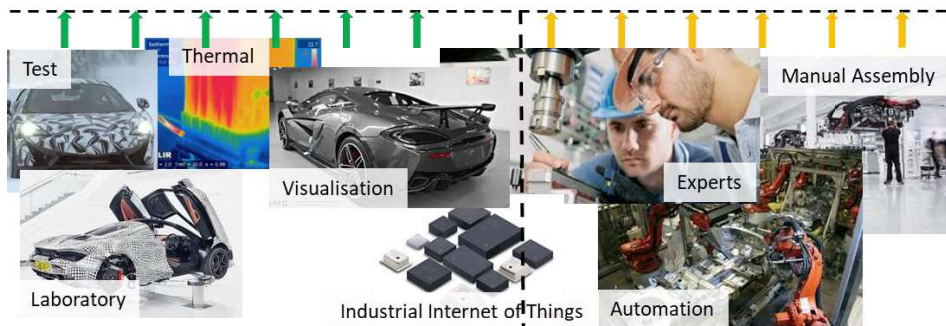

PHYSICAL DNA Product Process DNA

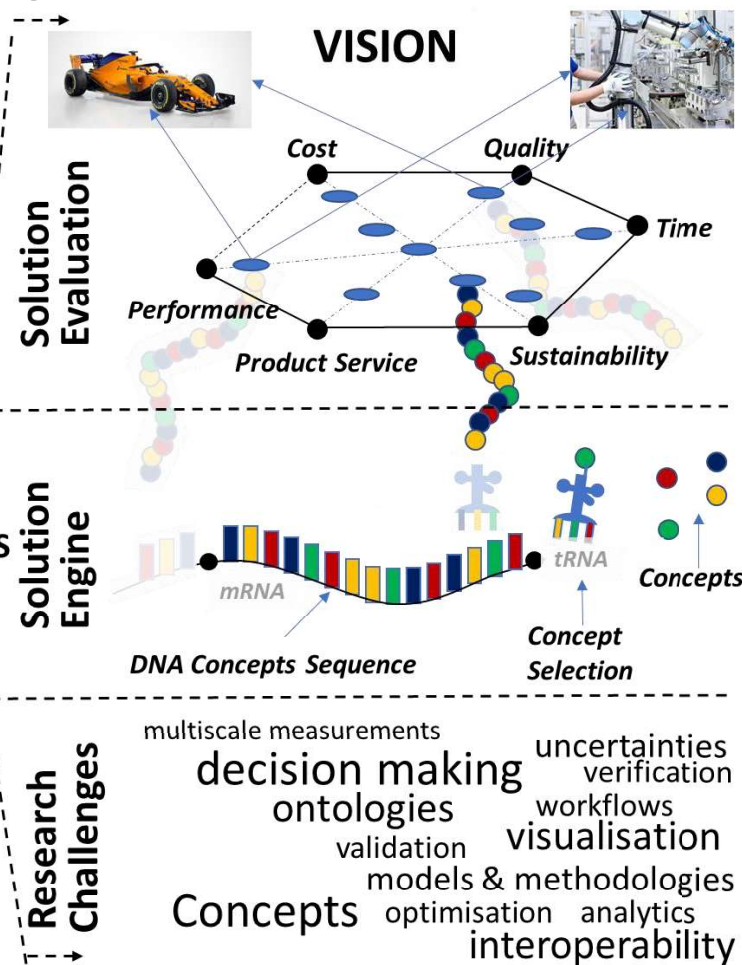



Too many variables to explore in full factorial!!

n levels/values

m variables

Need:

m^n studies

e.g. 5 levels for 10 variables

~ 10million alternatives

Not enough time & resource to explore, which results in overreliance on experience, tacit knowledge and existing solutions.



New Ways of Thinking... Inspiration from Nature



CONCEPT AND ETHOS

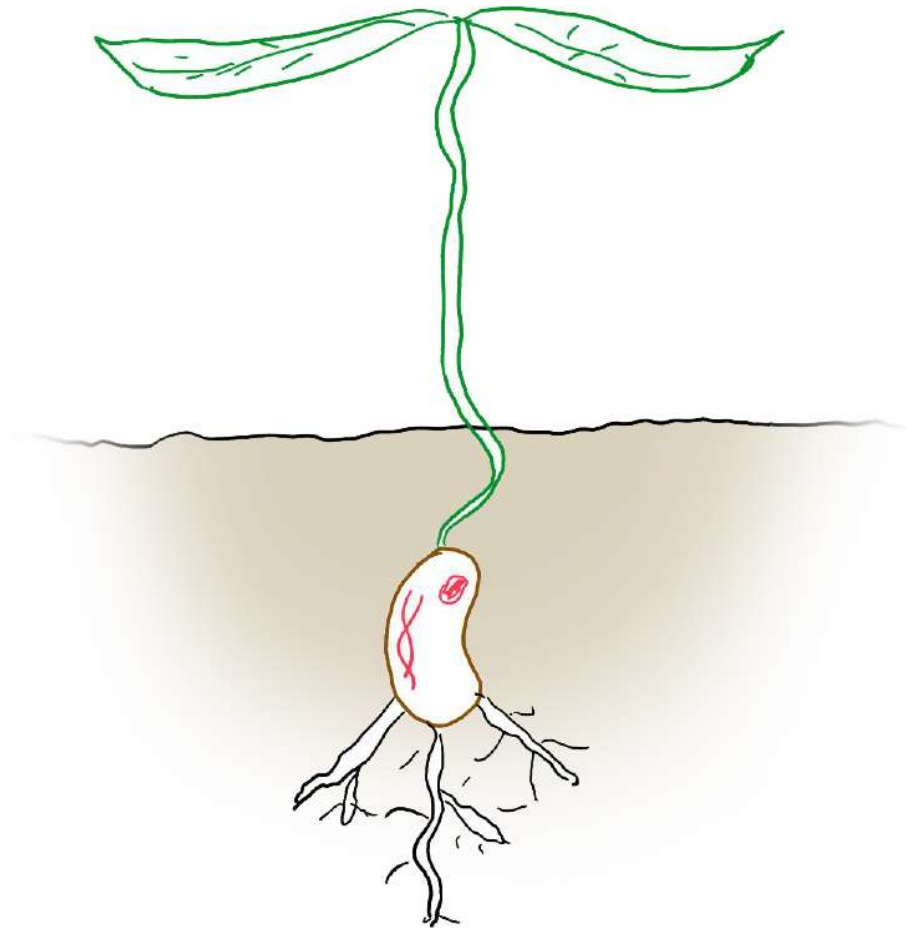

Generative Design for Additive Manufacturing Using A Biological Development Analogy

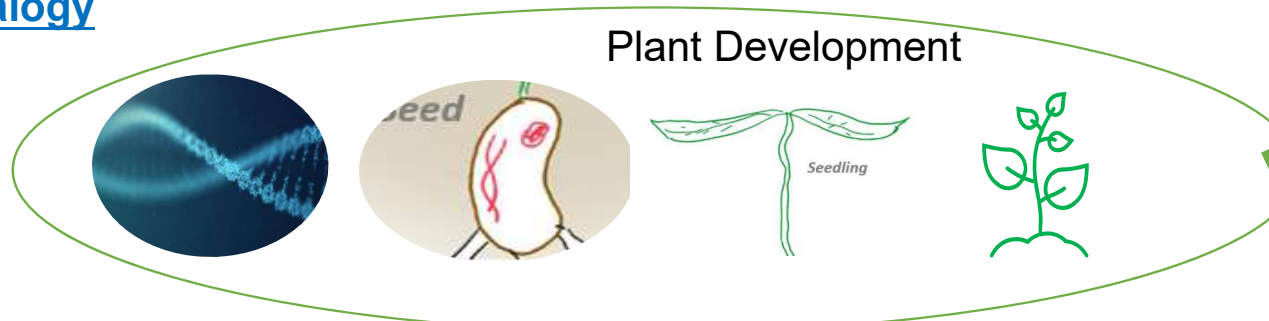

Observe and extract biological development processes

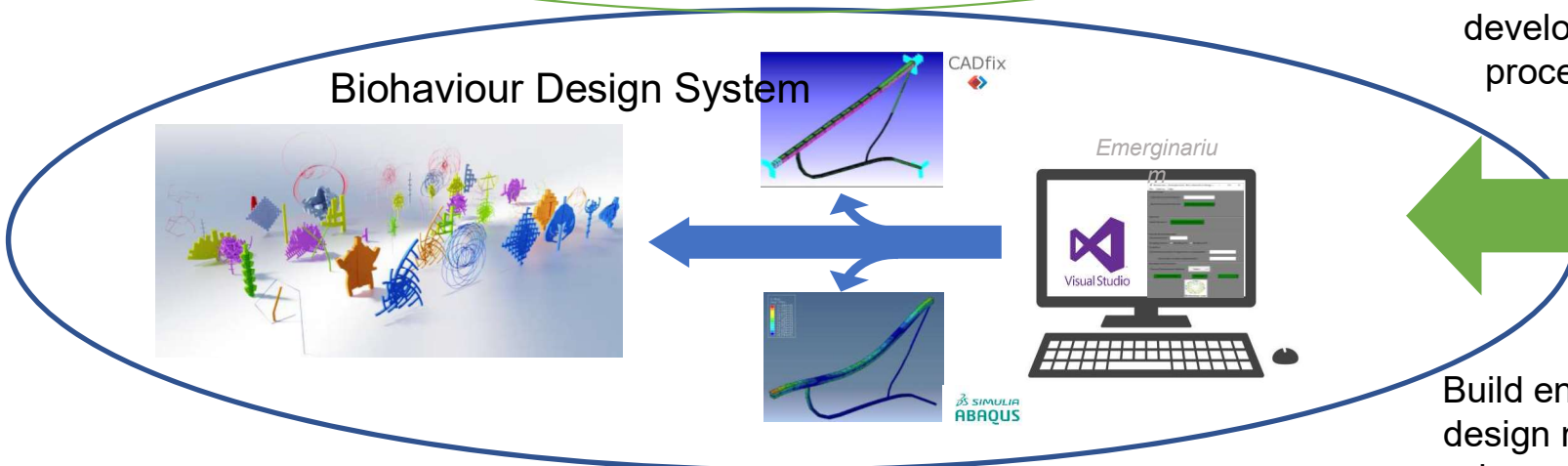

Build engineering design metaphors based on bio systems processes

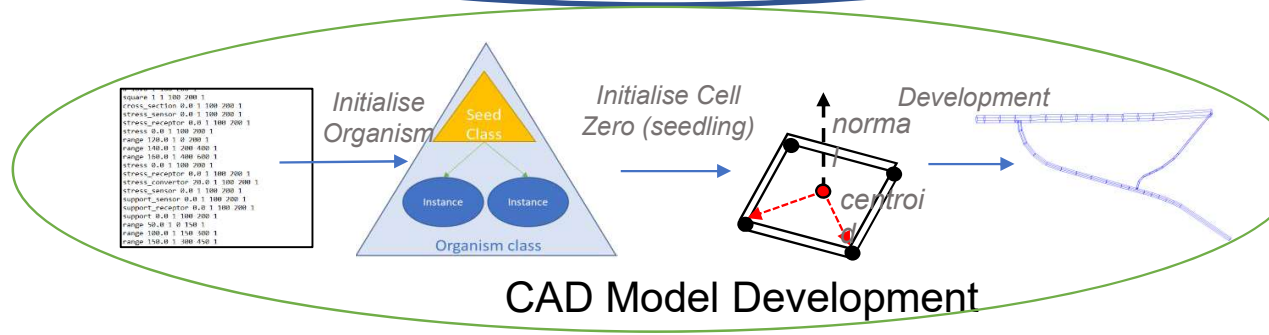

CAD Model Development

Re-Imagining Engineering Design

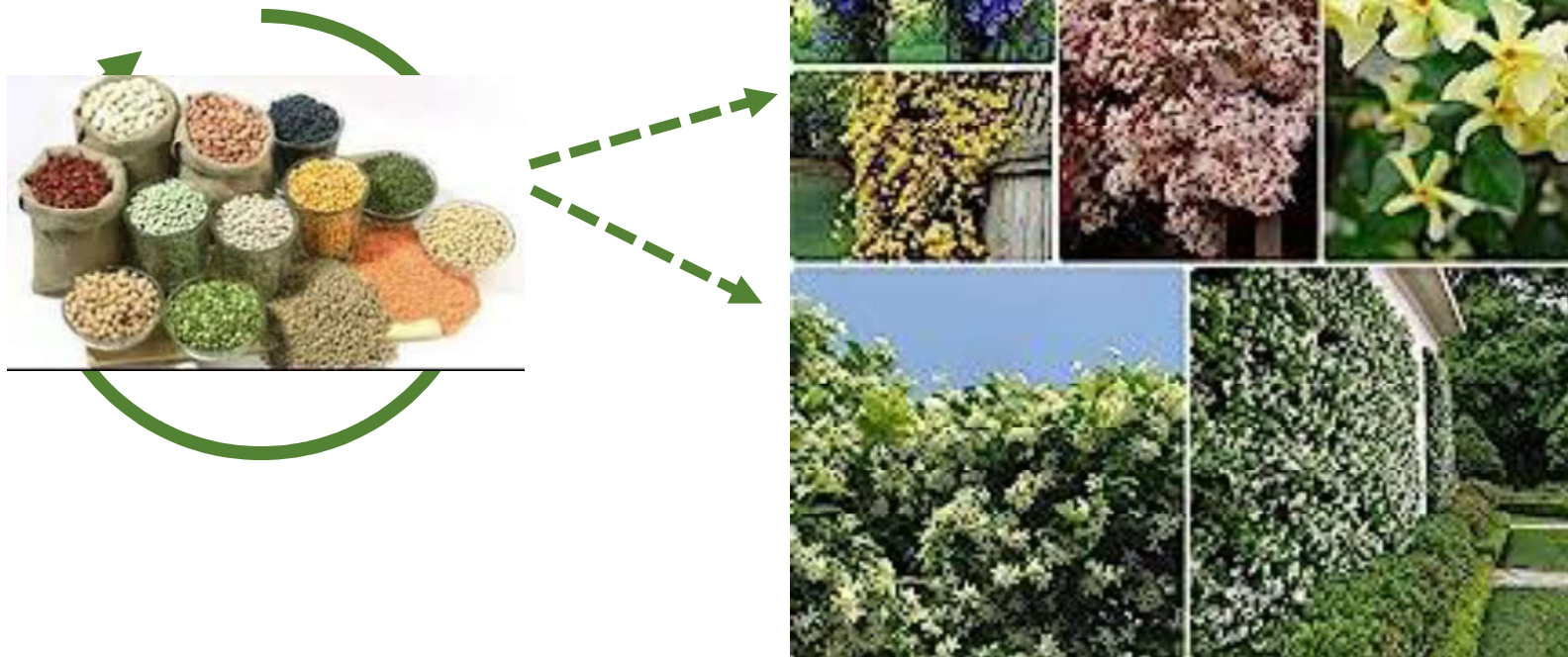

Re-Imagining Engineering Design



Consider a bridge...



Re-Imagining Engineering Design

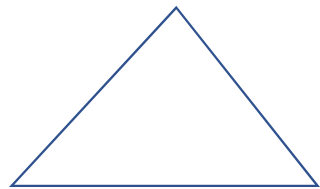

Single
Cell

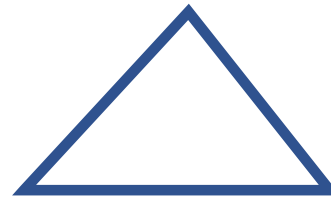

Behaviour encoded is for edges to 'harden' and form structural members e.g. as in a truss.

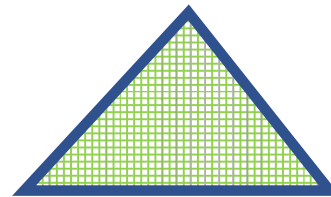

Behaviour encoded is for interior to 'harden' and form structural plate members, for example.



NeuroEvolution of Augmenting Topologies (NEAT): the Gene Regulatory Network (GRN)

Input

- Stress on 3 members of a cell

Output

- Changes in the area of members

Fitness

- Stress, Deflection and Volume (entire organism)

Next

- Multi objective implementation

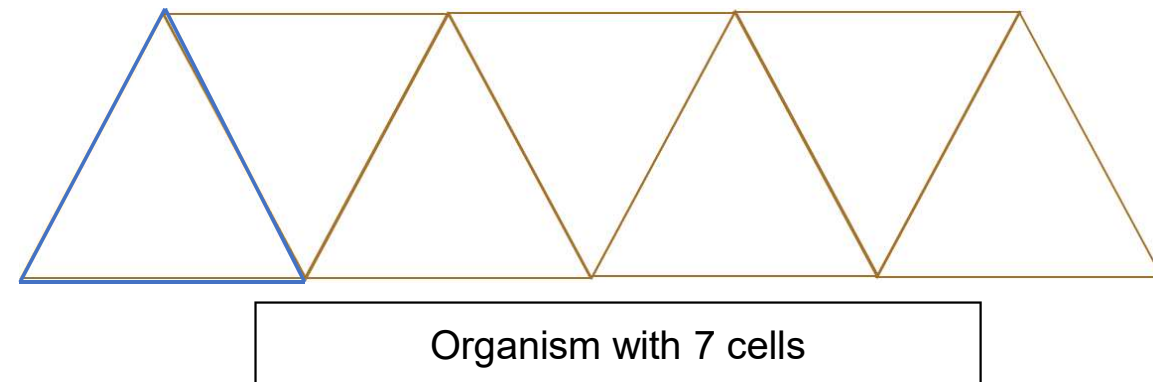
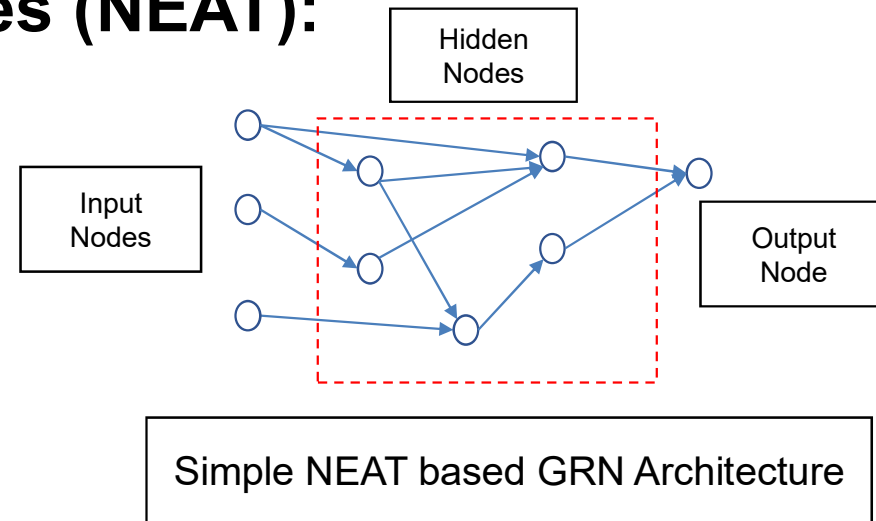

Re-Imagining Engineering Design



We can evolve solutions for given scenarios e.g. 2D truss with in-plane load...

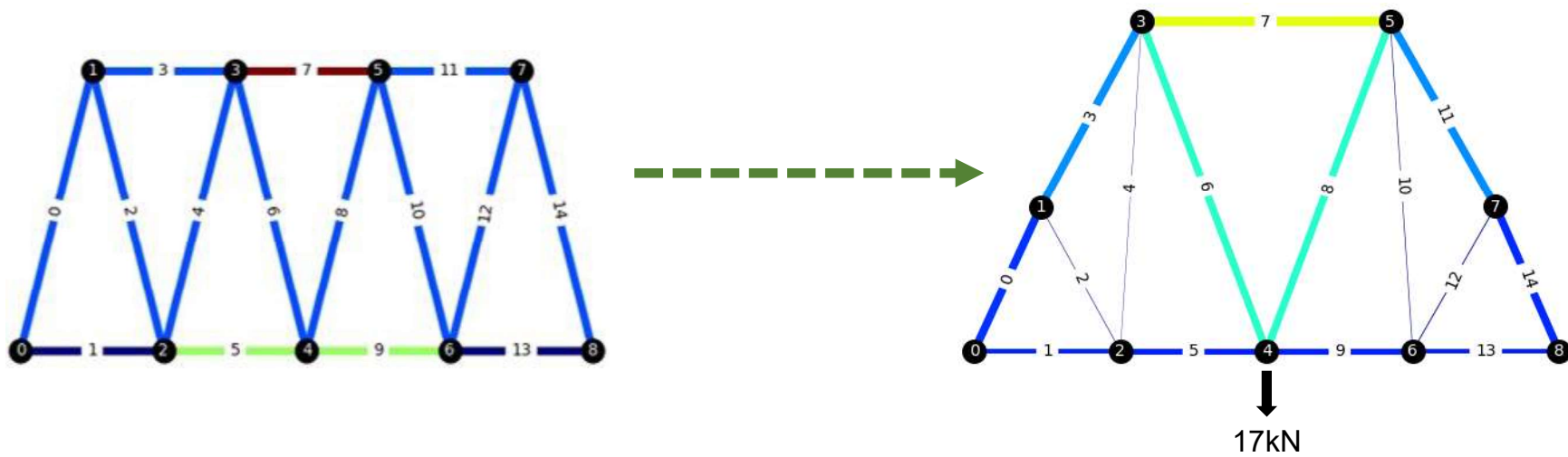

Re-Imagining Engineering Design



- Explore lots of solutions...

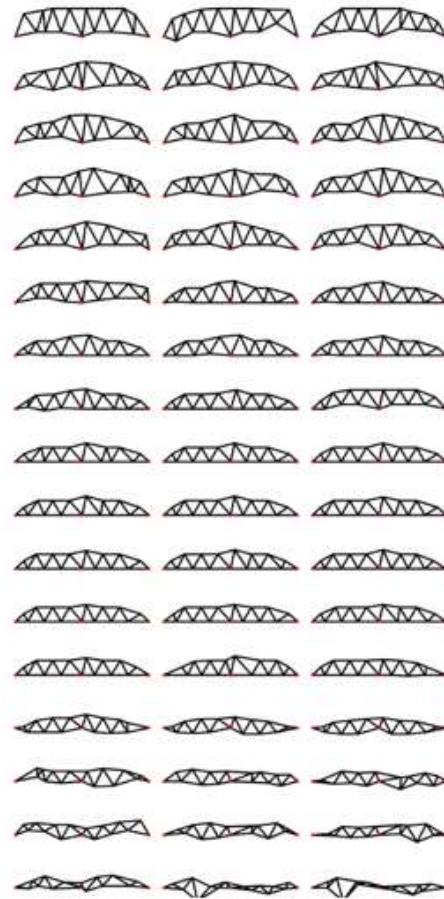

Re-Imagining Engineering Design



We can evolve solutions for given scenarios e.g. 2D truss with in-plane load...

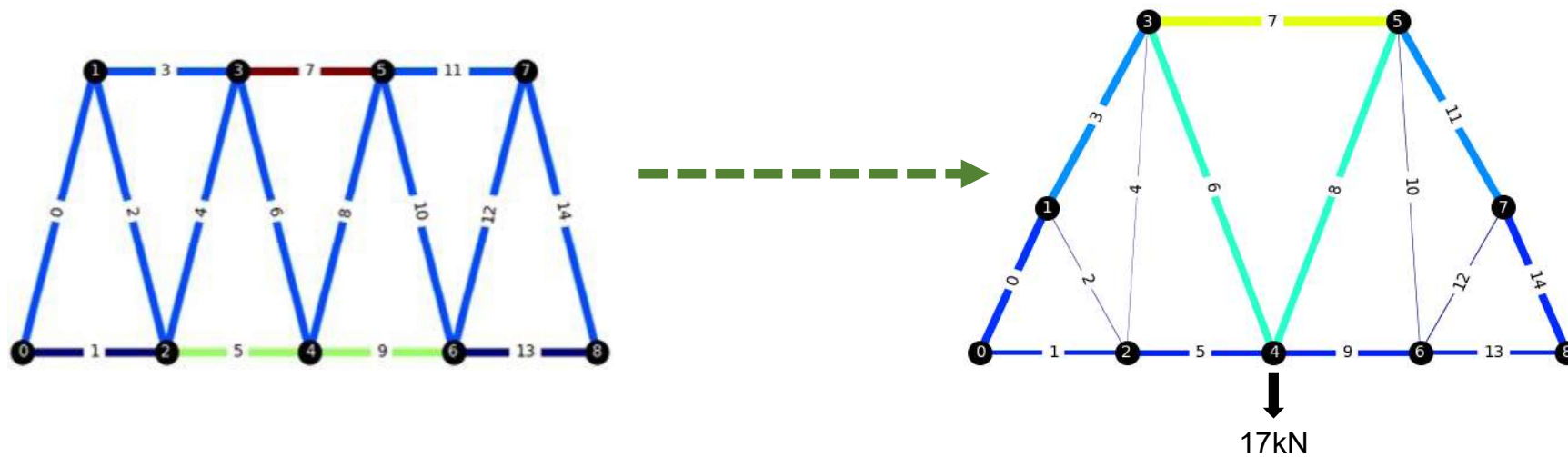

Initial Seedling evolves to become a good seed

Re-Imagining Engineering Design

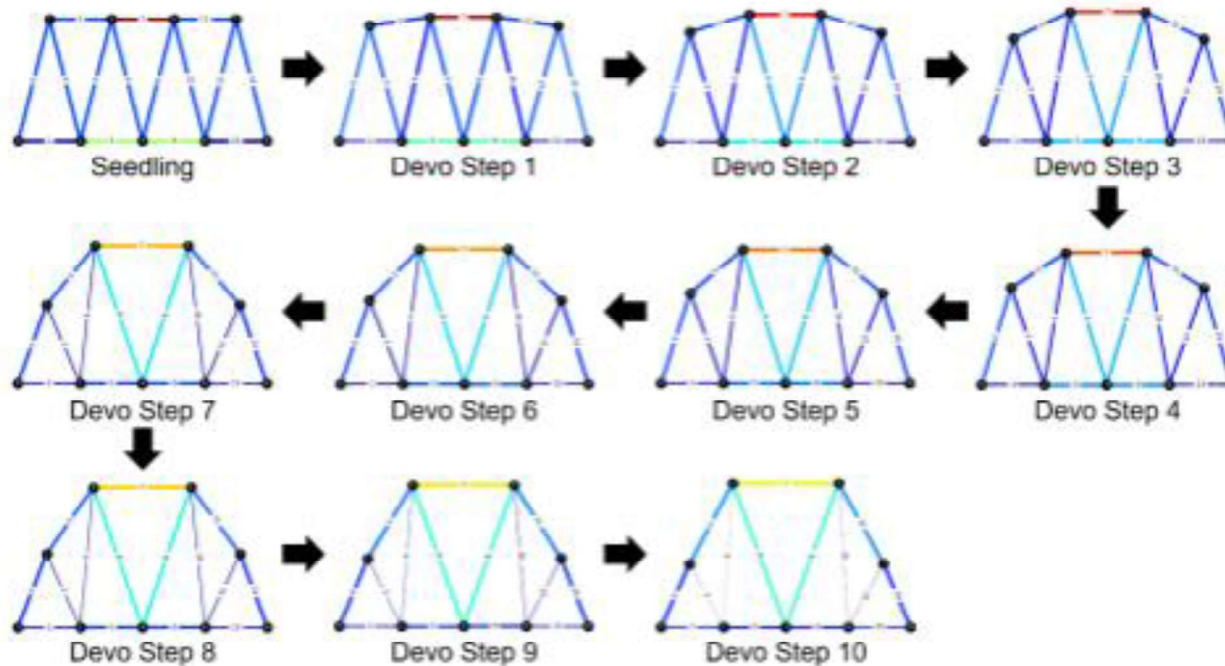

Figure 6: Development Steps for Best Performing GRN using Cell as Vertex and Edge

The seed responds to loads according to the GRN (its genes) and each step it grows/develops until maturity.

Re-Imagining Engineering Design



Gen: 0 Pop: 0 Itr: 0
SE=1.0, Vol=1.0

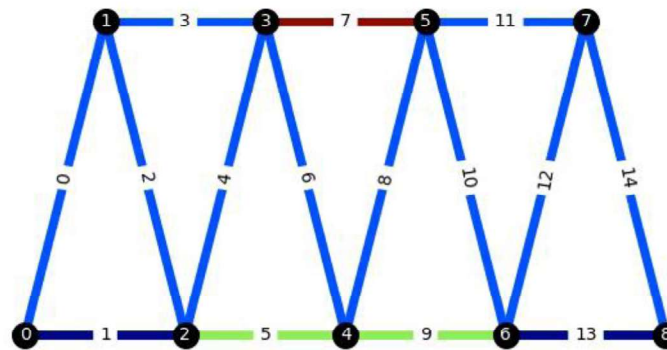

Re-Imagining Engineering Design

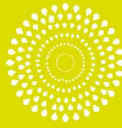

We can use seed in many variations for very rapid solutions...

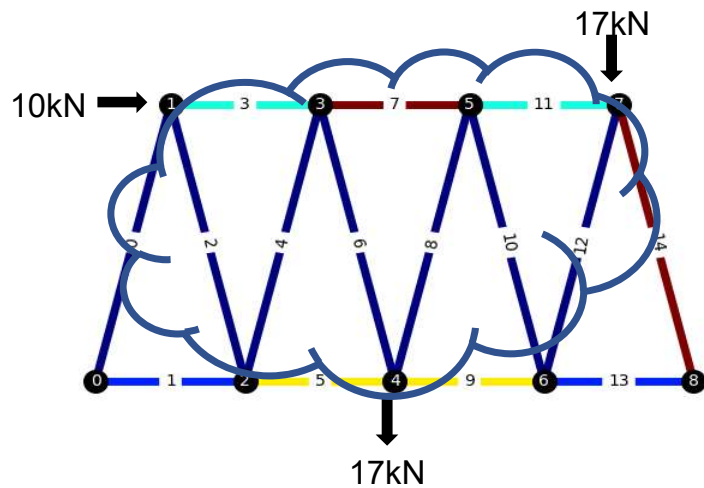

From scratch = 15 minutes

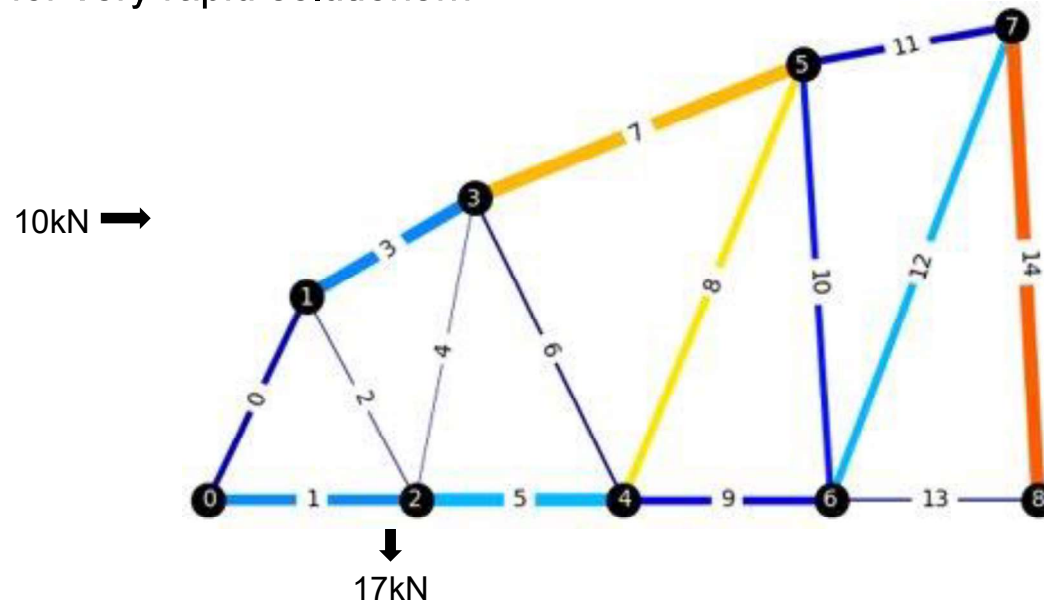

From pre-evolved seed = 0.018 seconds

Pre-evolved seed solution speed up factor of approx. **50,000**



The Cyber Cell & Supporting Interoperability.

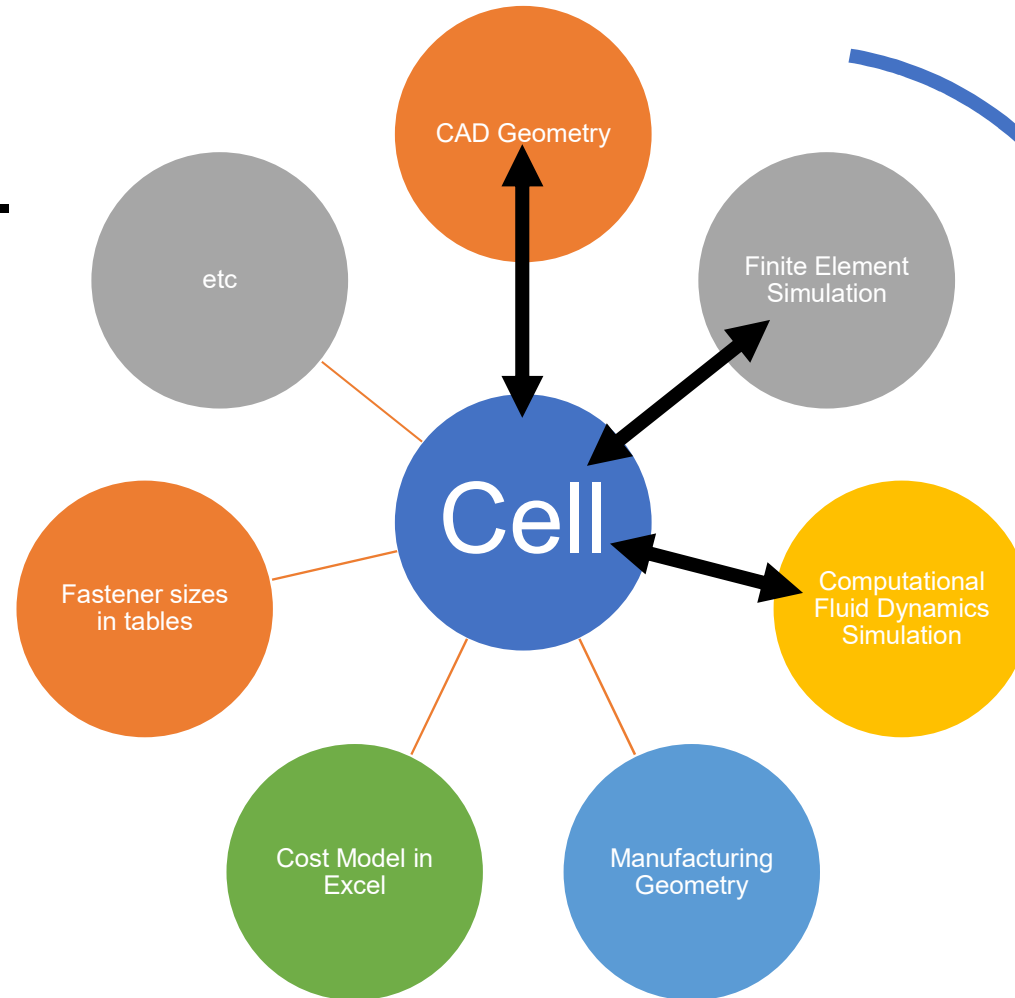

Allows for a natural interoperable system.

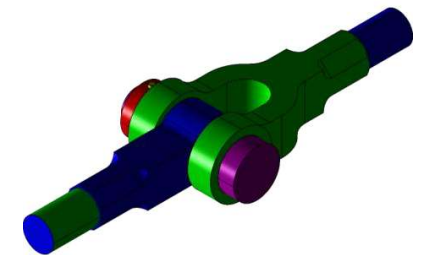

Re-Imagining Engineering Design

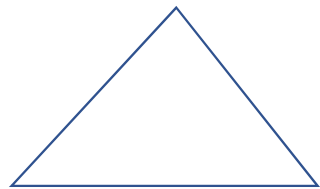

Single
Cell

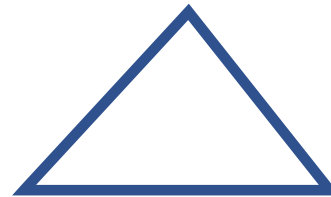

Behaviour encoded is for edges to 'harden' and form structural members e.g. as in a truss.

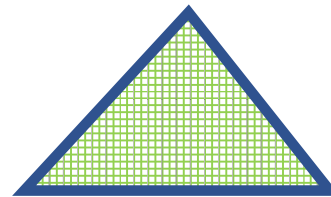

Behaviour encoded is for interior to 'harden' and form structural plate members, for example.



Coupled Heat and Structural Analysis

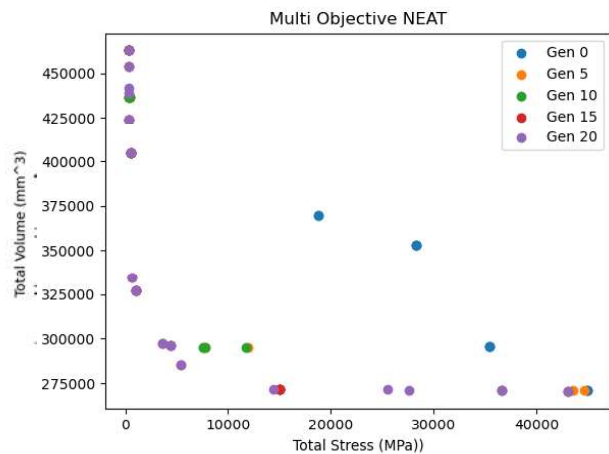

Fitness: Minimise volume & total stress

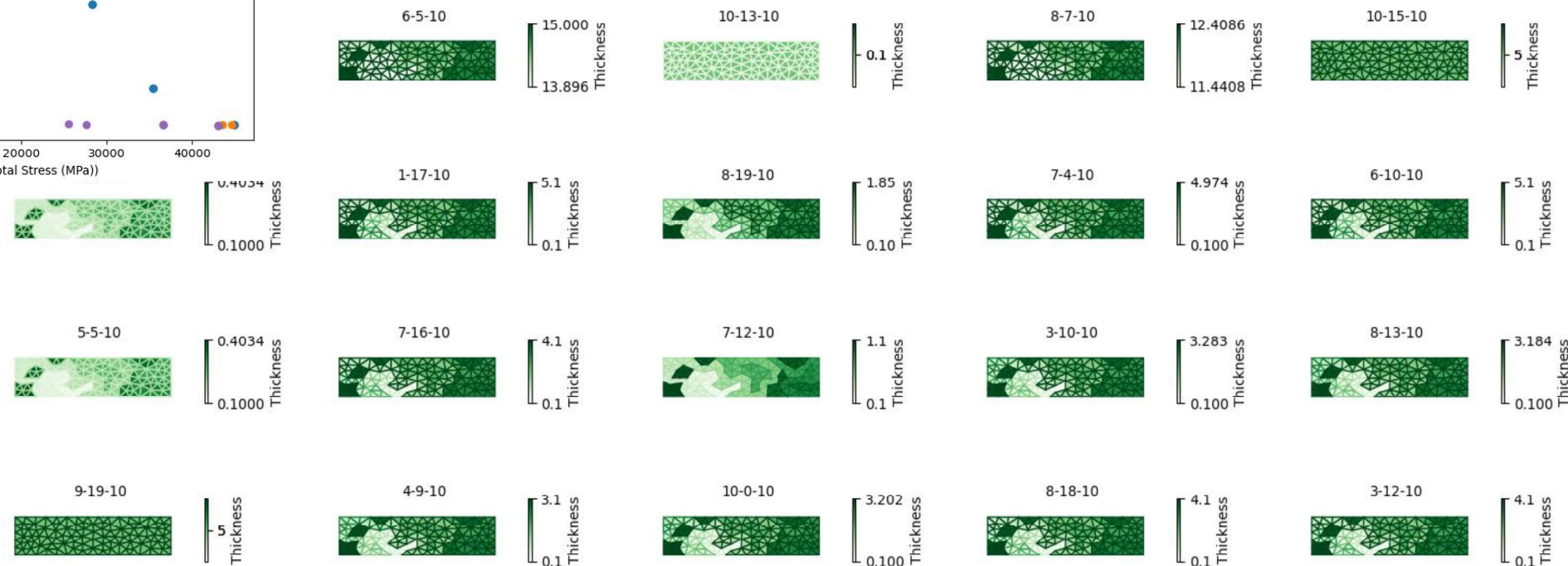

IMechE

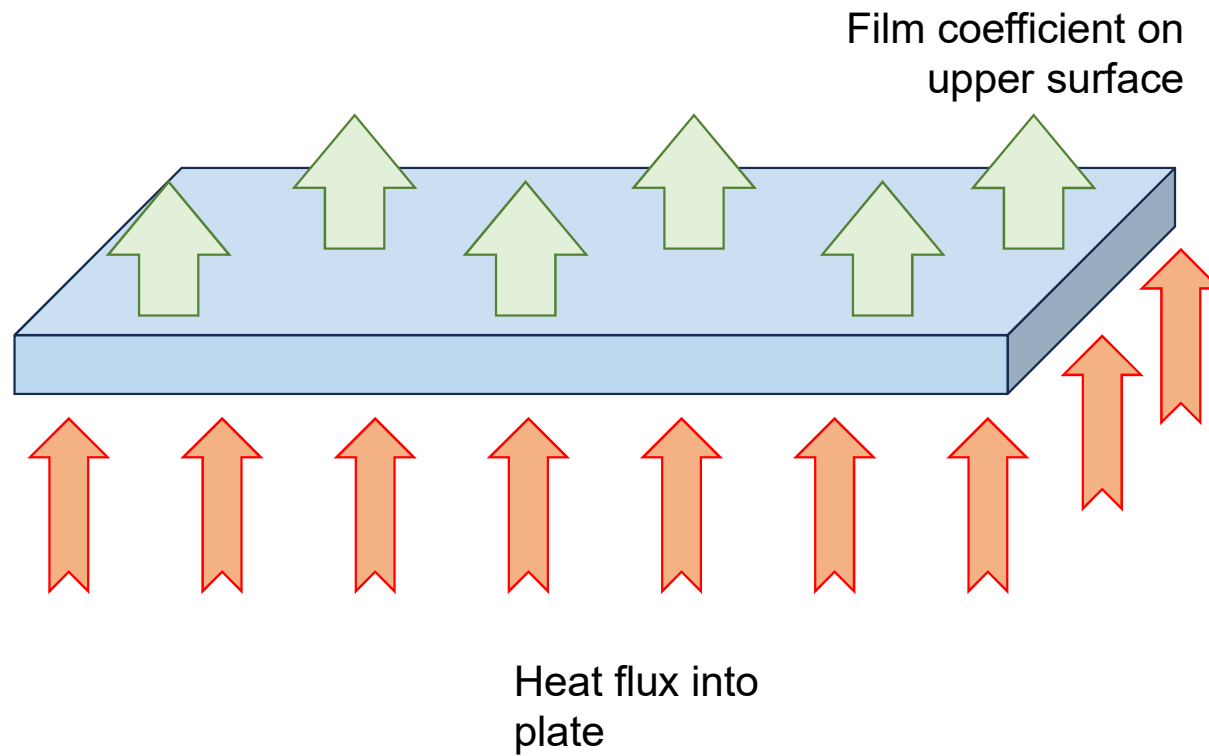

Fitness Criteria:
Average node temperature
Total volume

Network Input:
Node temperatures

Network Output:
Fin addition

Trigger to add fin = 0.7

Re-Imagining Engineering Design

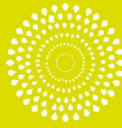

Pareto Orgs

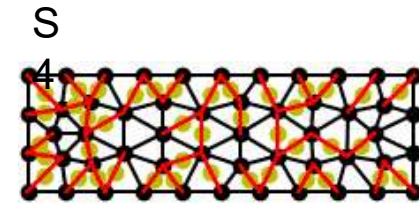
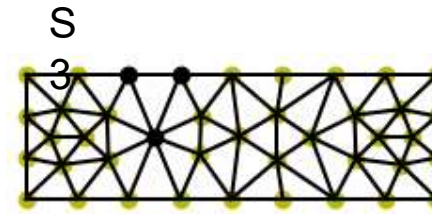
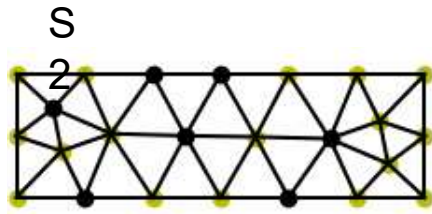
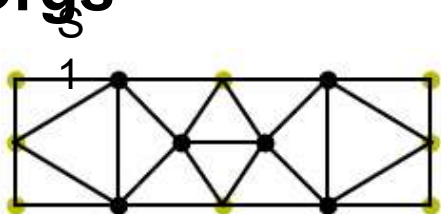
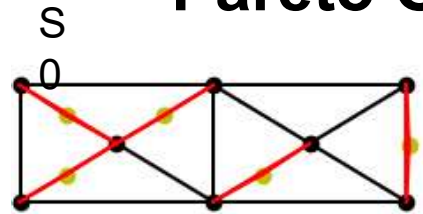

Volume (mm3)	Average Node Temp (K)
1500	99.93533125
1500	99.93533125
1500	99.93533125
1500	99.93533125
1500	99.93533125
1606.25	99.65934
1606.25	99.65934
1606.25	99.65934
1606.25	99.65934
1606.25	99.65934
1712.5	99.65563625
1718.75	99.13187875
1718.75	99.13187875
1718.75	99.13187875
1718.75	99.13187875
1818.75	99.08400125
1931.25	98.3555425
1931.25	98.3555425
2037.5	98.35353

Volume (mm3)	Average Node Temp (K)
1500	99.99395857
1500	99.99395857
1578.125	99.86140857
1578.125	99.86140857
1578.125	99.86140857
1656.25	99.78450357
1656.25	99.78450357
1674.749341	99.72260357
1690.037298	99.70660286
1697.403695	99.66406714
1697.403695	99.66406714
1697.403695	99.66406714
1697.403695	99.66406714
1697.403695	99.66406714
1738.557389	99.42856
1738.557389	99.42856
1762.5	99.356635
1762.5	99.356635
1859.903695	98.51080929
1859.903695	98.51080929

Volume (mm3)	Average Node Temp (K)
1500	99.90862708
1500	99.90862708
1500	99.90862708
1500	99.90862708
1500	99.90862708
1529.950734	99.89635833
1548.593728	99.8802275
1604.931299	99.68906708
1624.837089	99.63926958
1649.391111	99.58243167
1698.041171	99.43197583
1698.041171	99.43197583
1765.442856	99.33103875
1767.830966	99.18921042
1767.830966	99.18921042
1874.134515	99.15163167
1874.134515	99.15163167
1884.917762	98.63502208
1930.608859	98.47862375
1931.726624	98.47491

Volume (mm3)	Average Node Temp (K)
1500	99.96779293
1500	99.96779293
1540.314389	99.85653805
1543.9426	99.82017878
1543.9426	99.82017878
1637.32799	99.5317978
1637.32799	99.5317978
1652.518128	99.51227073
1678.183276	99.43534195
1715.770032	99.43092902
1738.468291	99.27781098
1798.018272	99.19019756
1821.269151	99.17507902
1845.071098	99.08798341
1845.071098	99.08798341
1874.601794	98.80523146
1918.409015	98.72357488
1943.31677	98.63681171
1949.018351	98.56802634
1990.50249	98.56296

Volume (mm3)	Average Node Temp (K)
1500	99.97493365
1500	99.97493365
1500	99.97493365
1500	99.97493365
1500	99.97493365
1512.5	99.96953712
1512.5	99.96951519
1514.919541	99.91653788
1527.419541	99.91171058
1527.419541	99.91171058
1577.694331	99.73638596
1577.694331	99.73638596
1618.509716	99.68070077
1670.744807	99.52980654
1695.862239	99.44960212
1860.962335	99.17254962
1891.24913	98.67771558
1891.24913	98.67771558
1994.509918	98.56781327
1994.509918	98.56781327

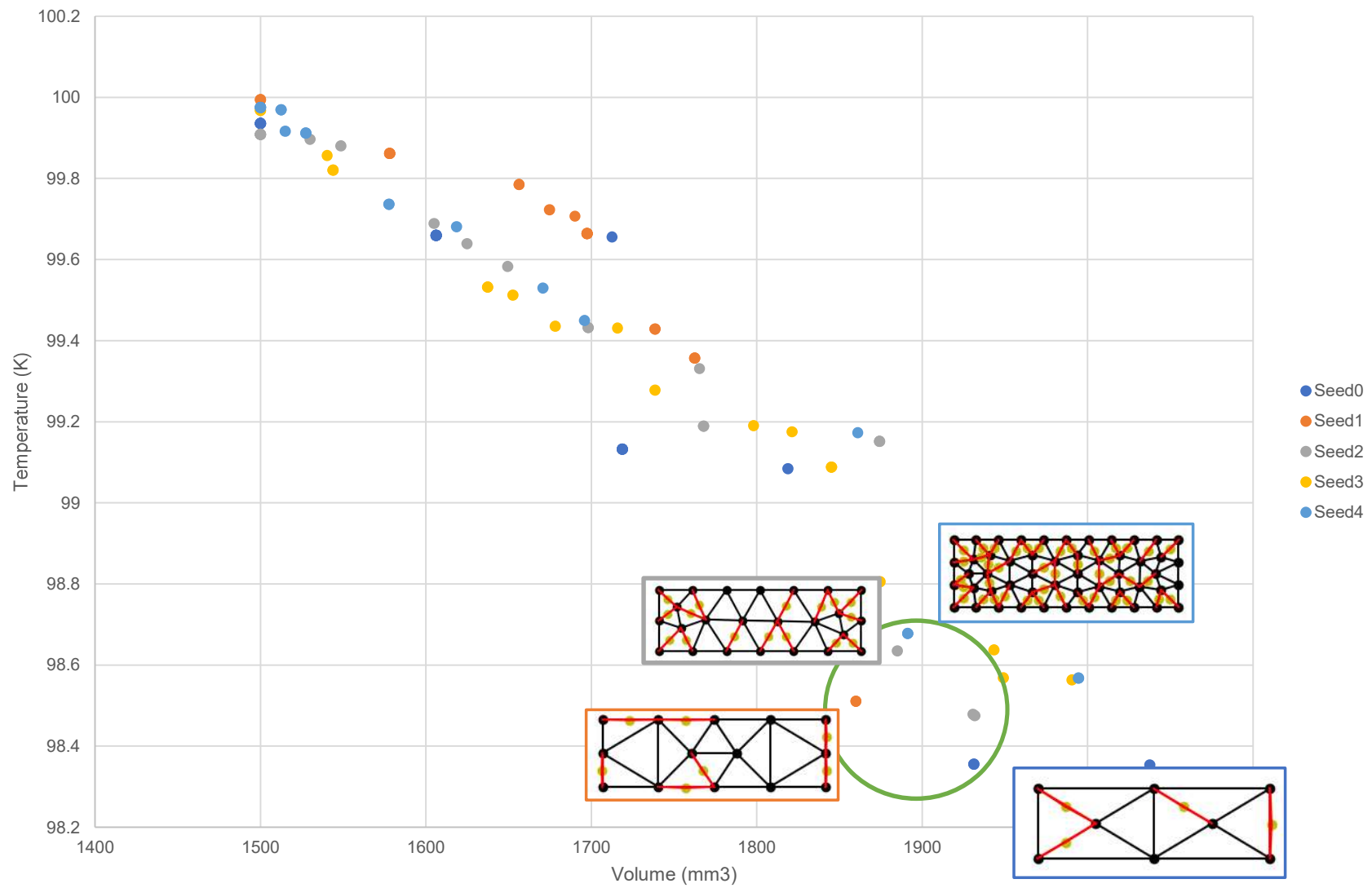

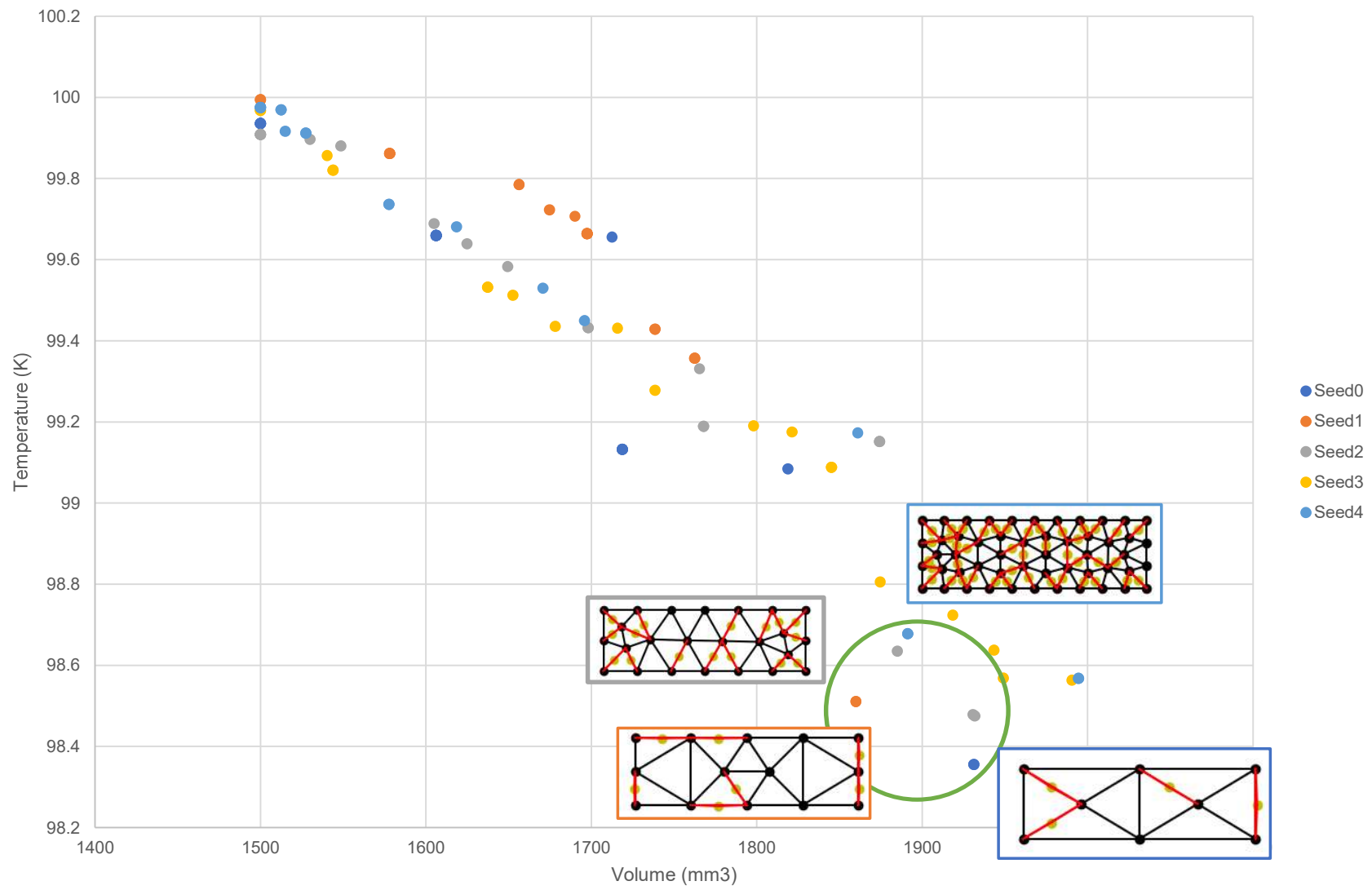



Heat Transfer

Adding geometry in response to environment and state

19:19:20
HFL*: 2.081
Vol: 6000

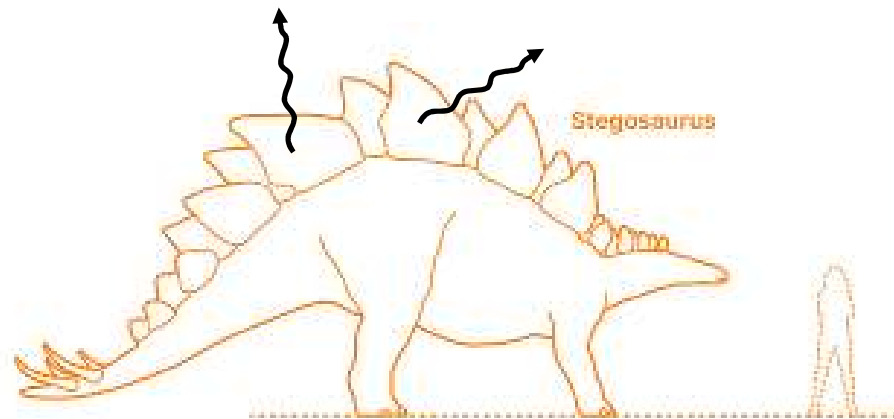
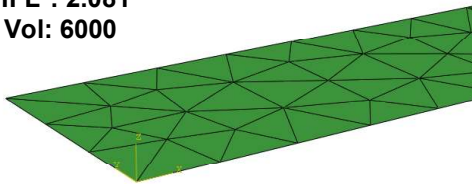

8:10:20
HFL*: 2.586
Vol: 6431

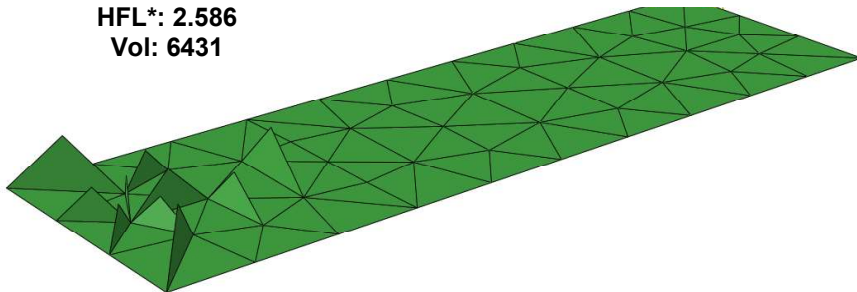

HFL*: 2.739
Vol: 6820

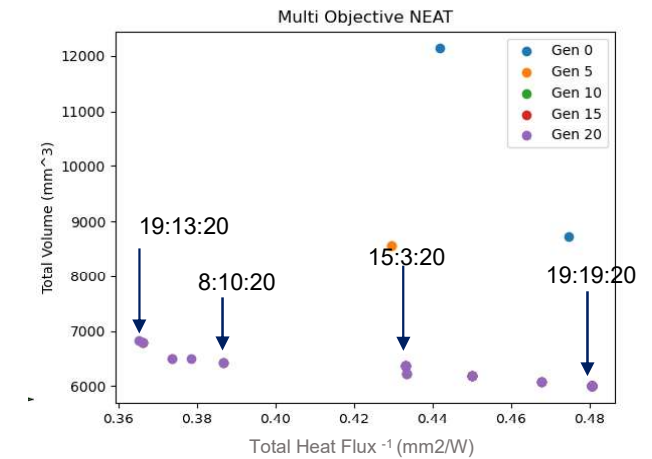
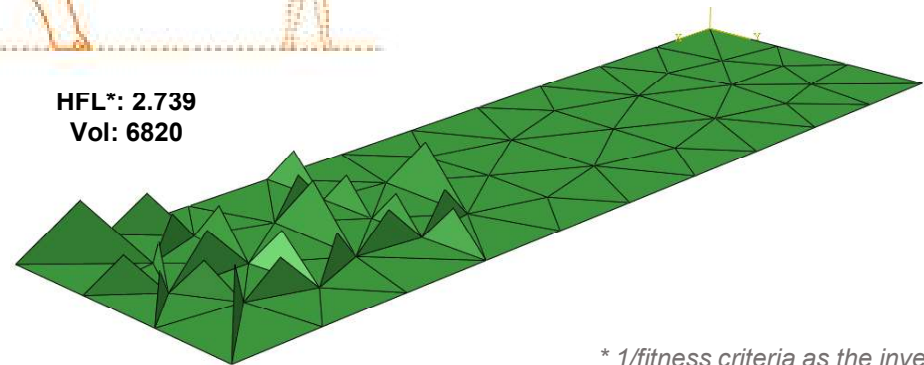

* 1/fitness criteria as the inverse was minimised in evo-devo

Re-Imagining Engineering Design



Significant challenges in creating detailed trabecular models, but concept can remain above this.
Significantly reduces model interoperability issues.

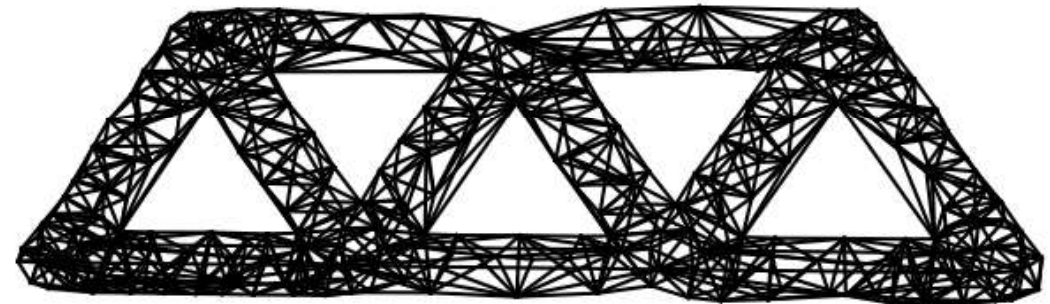
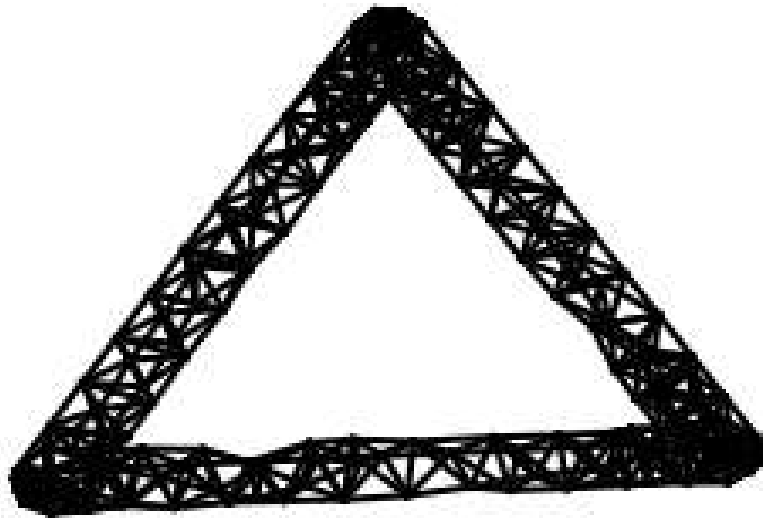

Re-Imagining Engineering Design

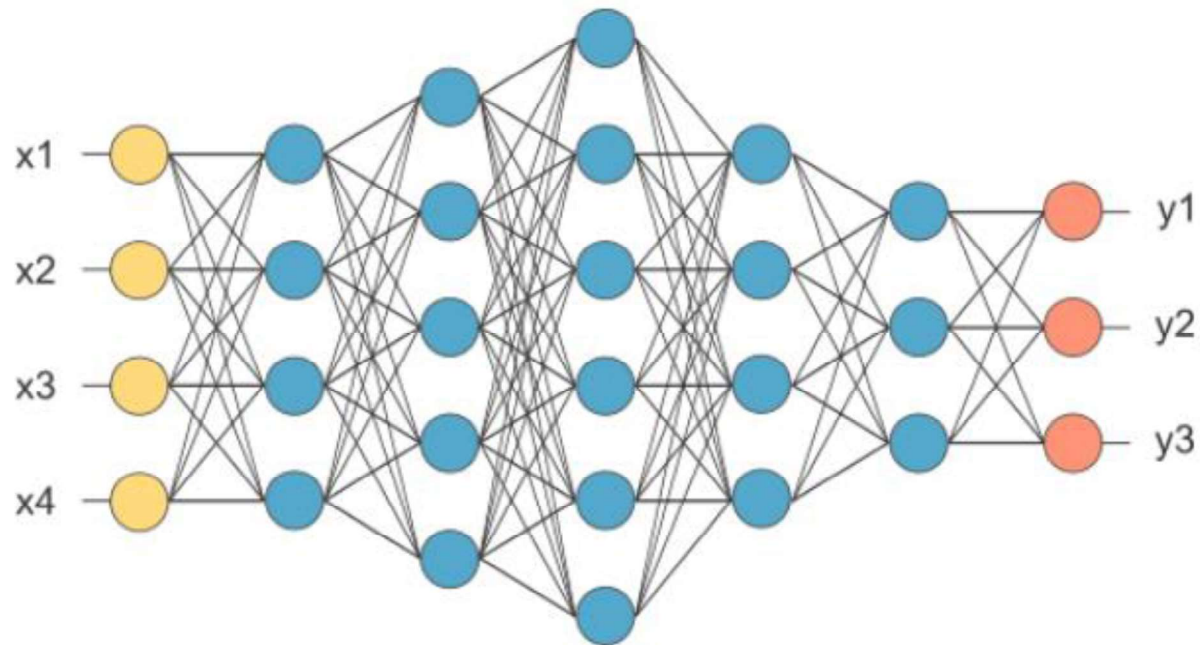

A new
representation of
the design!

https://colab.research.google.com/github/patbaa/demo_notebooks/blob/master/fully_connected.ipynb



Exemplar Projects



IMECHE SIMULATION AND MODELLING CONFERENCE 2023



With Special Thanks to the Project Team:

- Scott Robinson (UG Mech Eng)
- Ross Cockcroft (UG Aero Eng)
- Thomas Shannon (PDRA)
- Declan Nolan (Project Lead) (Academic)

Re-Imagining Engineering Design

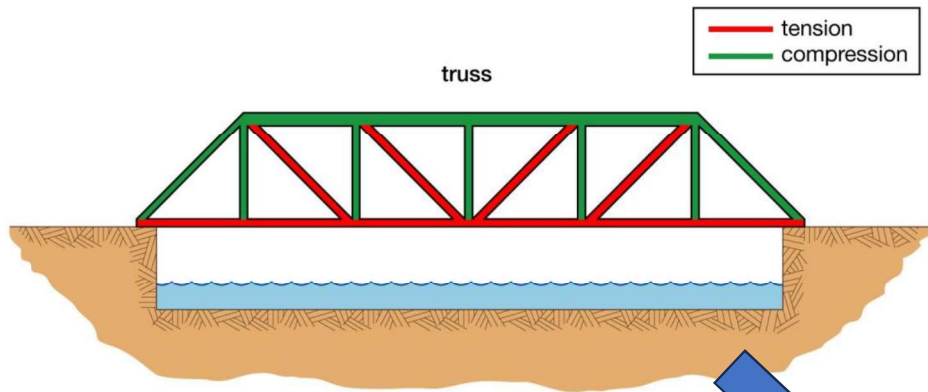

© Encyclopædia Britannica, Inc.



Re-Imagining Engineering Design

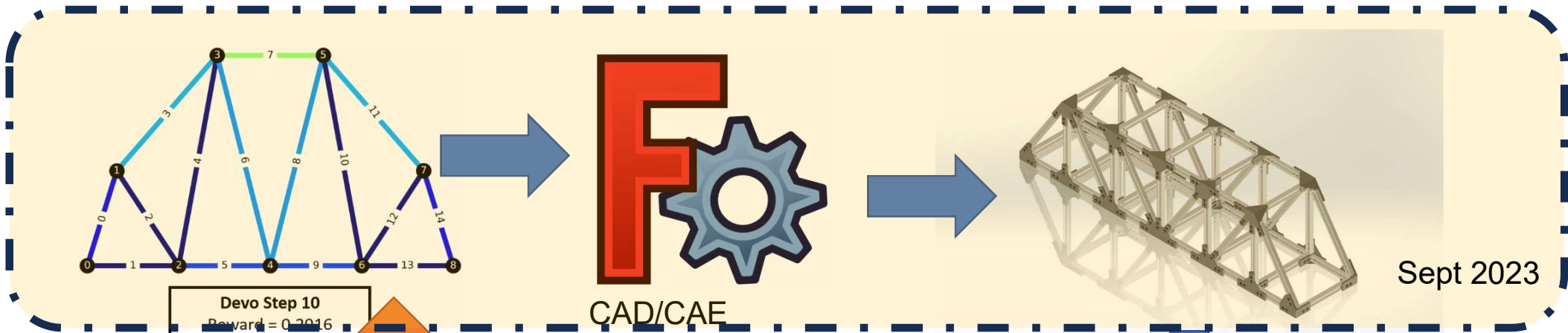

Devo Step 10
Reward = 0.2016
Strain Energy = 37.76%
Volume = -8.63%



CAD/CAE
Automation

Sept 2023

Mode
|



Physical
POC
Manufacture

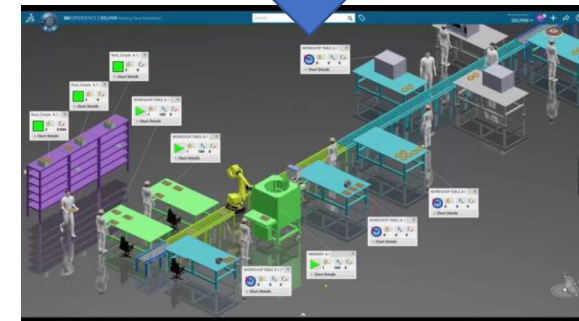

Factory
Simulation

Re-Imagining Engineering Design

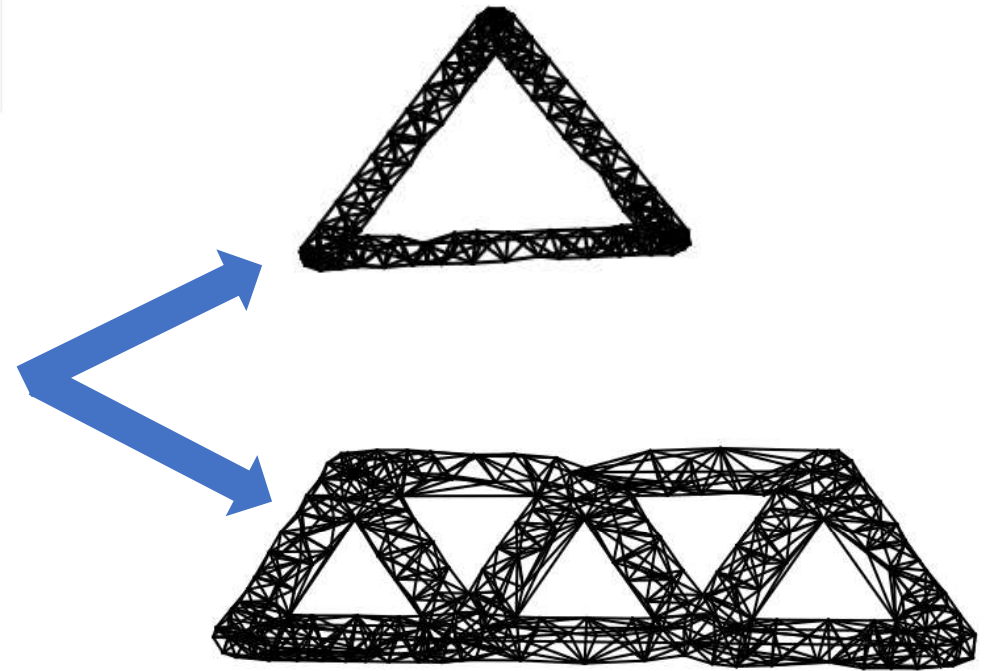
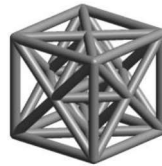
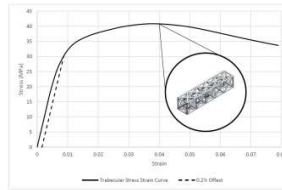
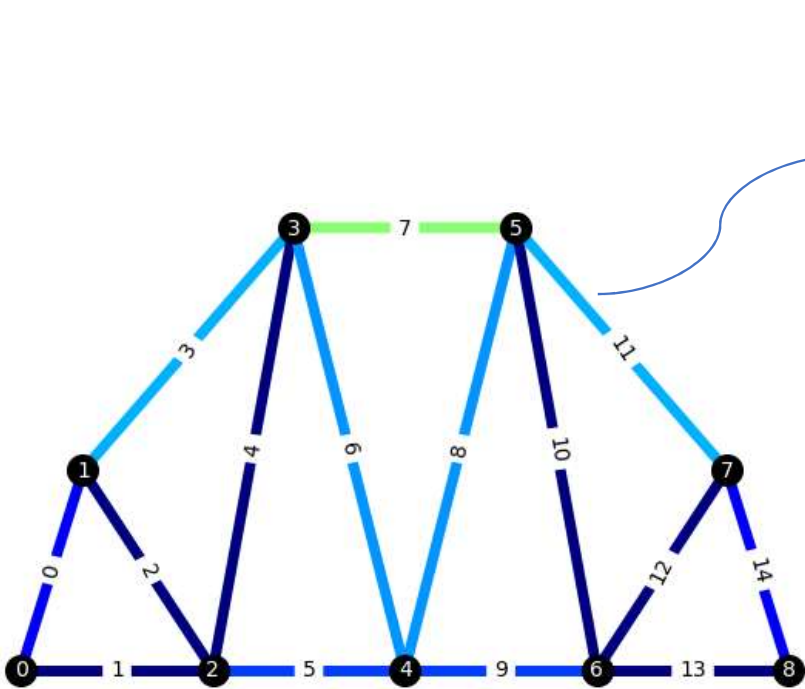
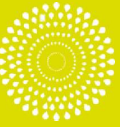

Simple cell 'shape' but underlying geometry can be very complex

Fully coherent single solid!

Re-Imagining Engineering Design



- ▶ Focused on joint design

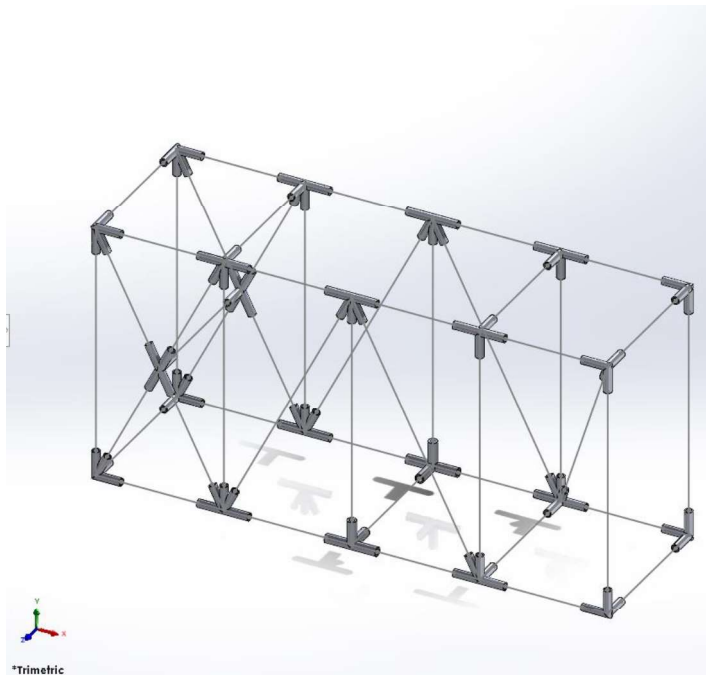



Project Objectives

- Build a full design to manufacture system truss prototype linked to Re-Imagining Engineering Design (RIED) research paper*
- Post-process AI-generated data using VBA excel code
- Automated CAD models for individual truss structures

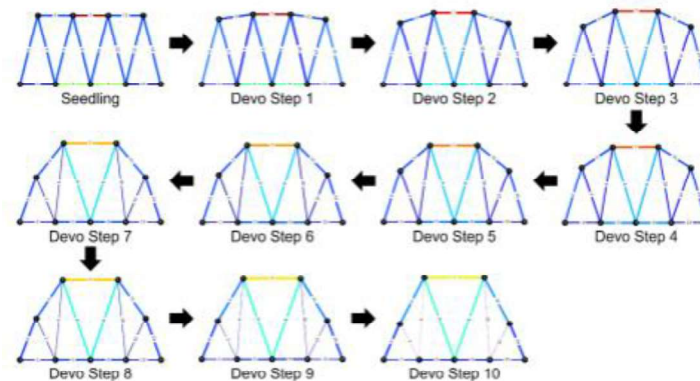

Figure 6: Development Steps for Best Performing GRN using Cell as Vertex and Edge



* - "GNN-EvoDevo: Bioinspired Generative Design via Evolutionary Development and Graph Neural Networks"

Refining Truss Joint CAD Modelling

Automated CAD Design Process



IMECHE SIMULATION AND MODELLING CONFERENCE 2023

Dynamic Variables

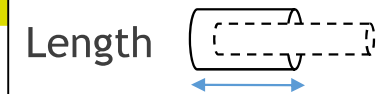

Adaptive Variables



Re-Imagining Engineering Design



- Using Angles lead to under defined “lines” instead of vectors
- Unreliable method
- Use points/coordinates instead of angles

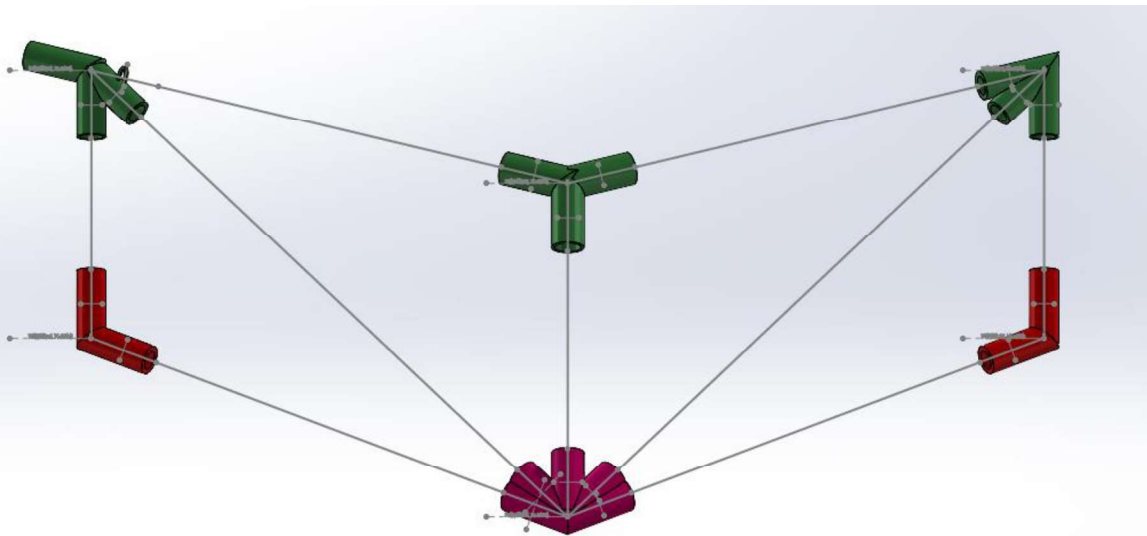

Physical Prototype Findings

Re-Imagining Engineering Design



• Annular Snap-Fit



Fig 1. Annular Snap-Fit Assembly (1-3)



Fig 2. Annular Snap-Fit Varying Diameter Thicknesses (1-3)



Fig 3. Annular Snap-Fit Reliance on Internal Print Quality



► Open “C” Snap-Fit (4-6)



Fig 4. “C” Snap-Fit Assembly (4-6)



Fig 5. “C” Snap-Fit Varying Thickness Legs



Fig 6. “C” Snap-Fit Broken Legs



Additive Manufacturing – 3D Printing

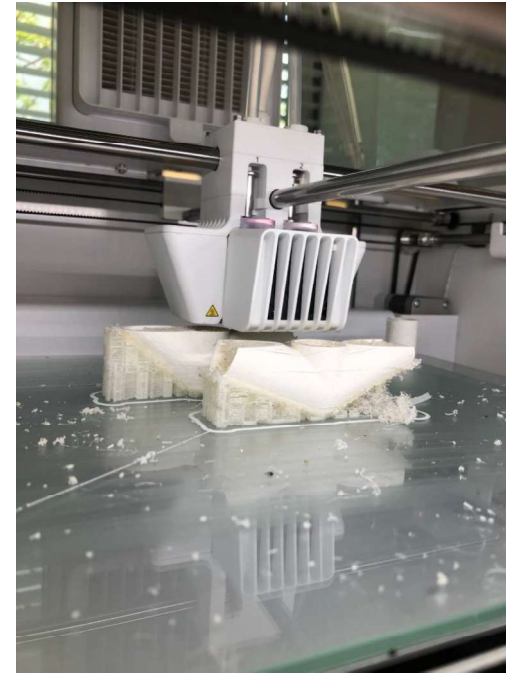

- Full manufacturing system given unique truss structures through prototyping (using 3D printers and plastic conduit).



Next Stage...

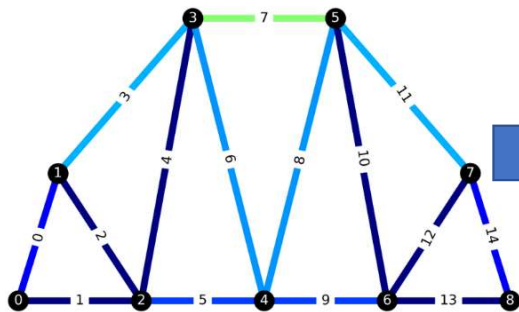

Devo Step 10
Reward = 0.2916
Strain Energy = 37.76%
Volume = -8.63%



CAD/CAE
Automation

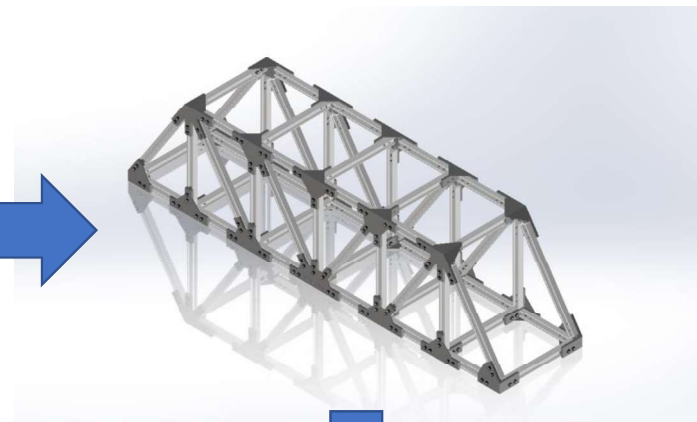

Mode



Physical
POC
Manufacture



Factory
Simulation

Dec 2023



Assembly Order and Fit Problems



Top joint cannot be added last



But assembly is possible...



Watch this space!!!

**Thank you all for your attention and
engagement.**