



Re-Imagining Engineering Design



Mark Price
Trevor Robinson
Frank Kirkland
Yan Jin
Karen Rafferty
Sakil Barbhuiya
Luis Freixial
Kate Van-Lopik
Paul Goodall
Andy Tyrrell

Paul Conway
Carmen Torres-Sanchez
Imelda Friel
Roísín McConnell
Andrew West
Stephen Kyle
Declan Nolan
Peter Kilpatrick
Radmehr Monfared
Simon Hickenbotham
Rahul Dubey



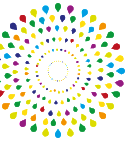

SIZE AND SHAPE OF RIED

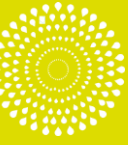

In numbers...

-
- Total Project Value is ~£11M (Full Cost) to run for 5 years.
 - 12 Academics from 3 Institutions: QUB, York, Loughborough.
 - Company partners include Airbus, Glen Dimplex, ITI, Rolls-Royce, Denroy, SAM UK, MTC, Far UK, OxMet, Bombardier
 - EPSRC Grant of £7.2M
 - Total Industrial Partner support to value of £1.5M
 - 10+ PDRA across the three sites.
 - Academic & Industrial support brings 14 PhD studentships

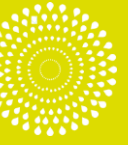

In Geographical spread...

- Partnership drawn from across UK.

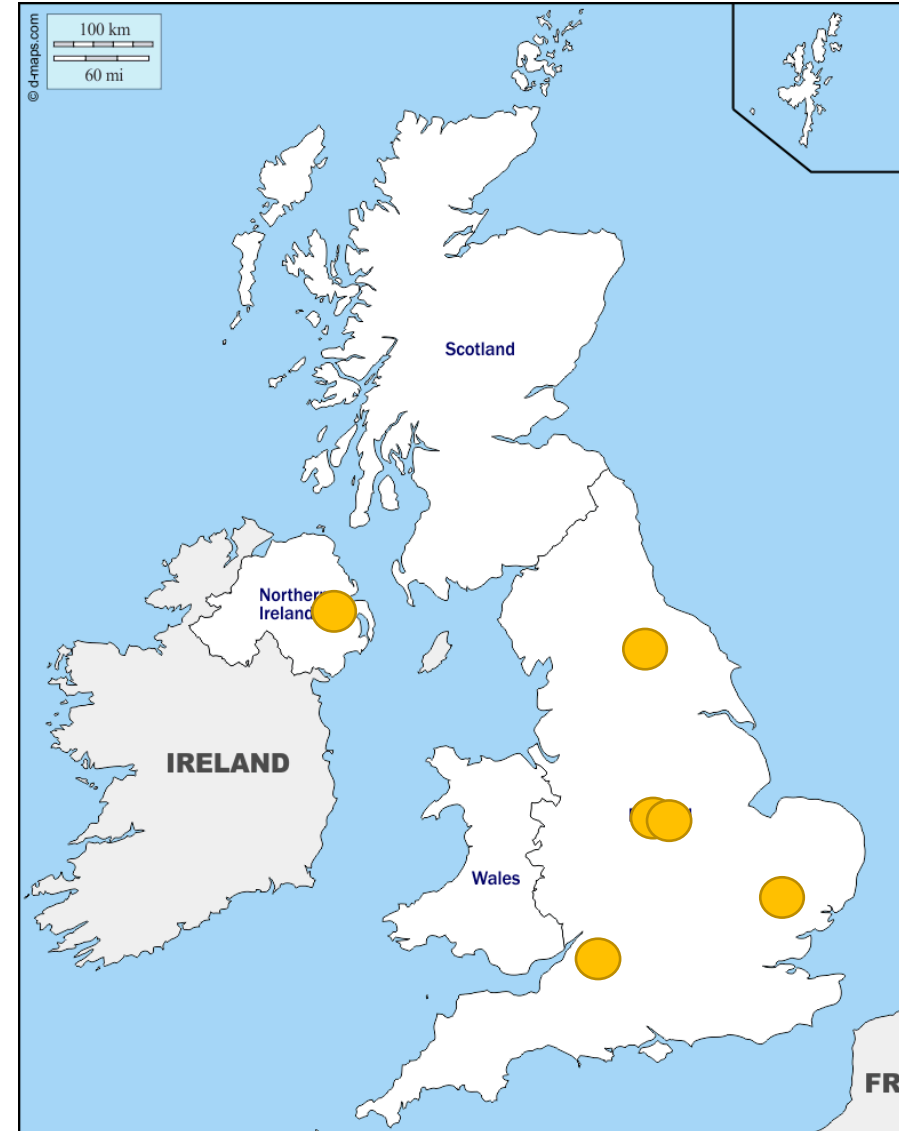

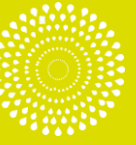

In Sectors...

-
- Aerospace
 - Automotive
 - Manufacturing
 - Medical Devices
 - Energy & Heating
 - White Goods

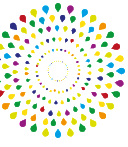

PROBLEM DESCRIPTION



What is physical is only the tip of the iceberg!



Wood capped with steel

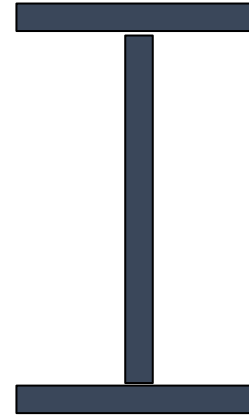

Steel I-Beam

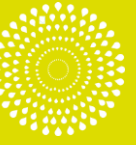

Function influences form (or form follows function)

$F(x, y, z, t, \text{cost, material, process...})$

What we can see in 3D

N-dimensions

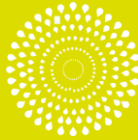

Top-Down Design

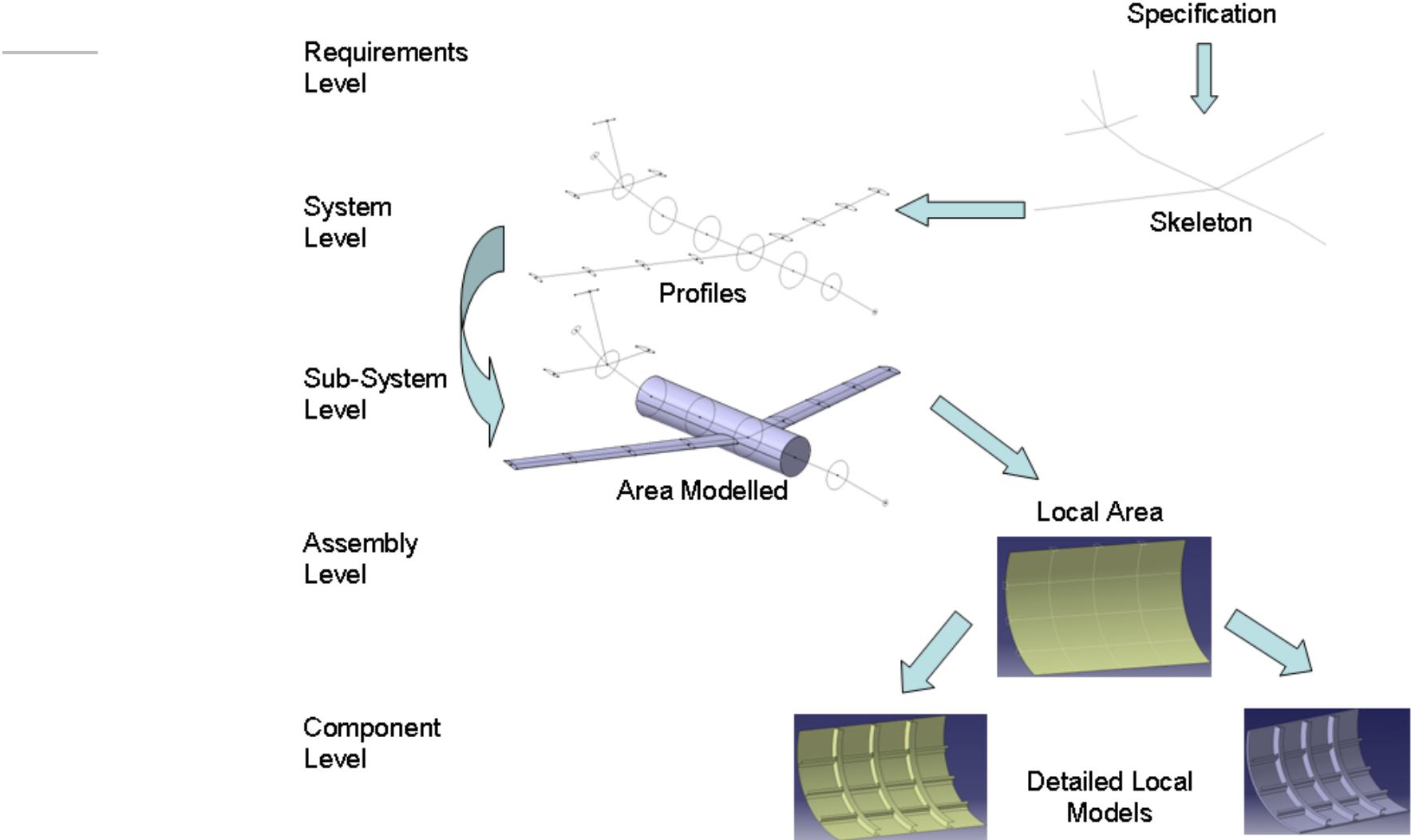



Building Complex Systems 1.- Engineer's approach

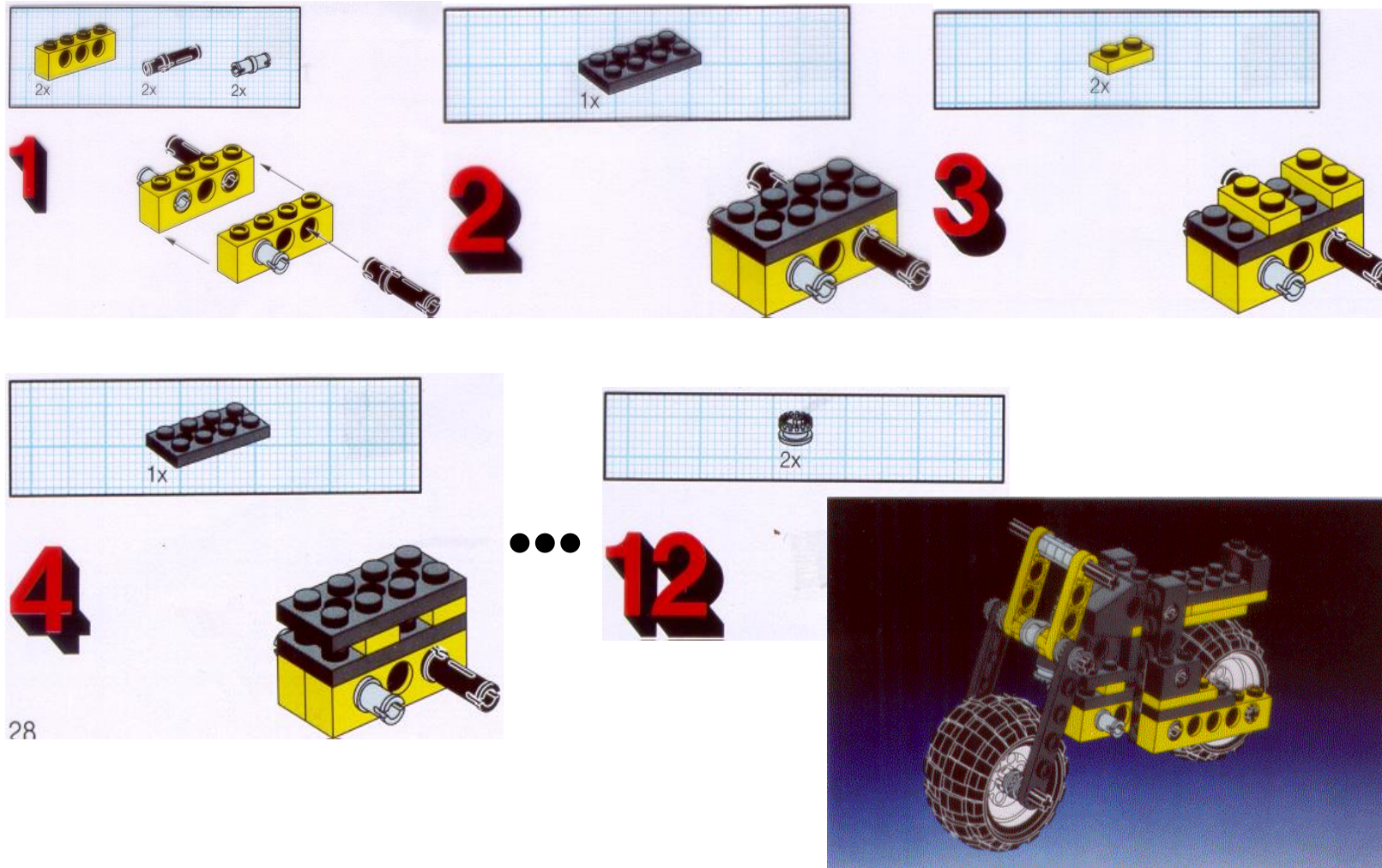

Different component designs for all of the different functions a system requires.

Specific parts:
One part, one job.



Manage data and understand relationships

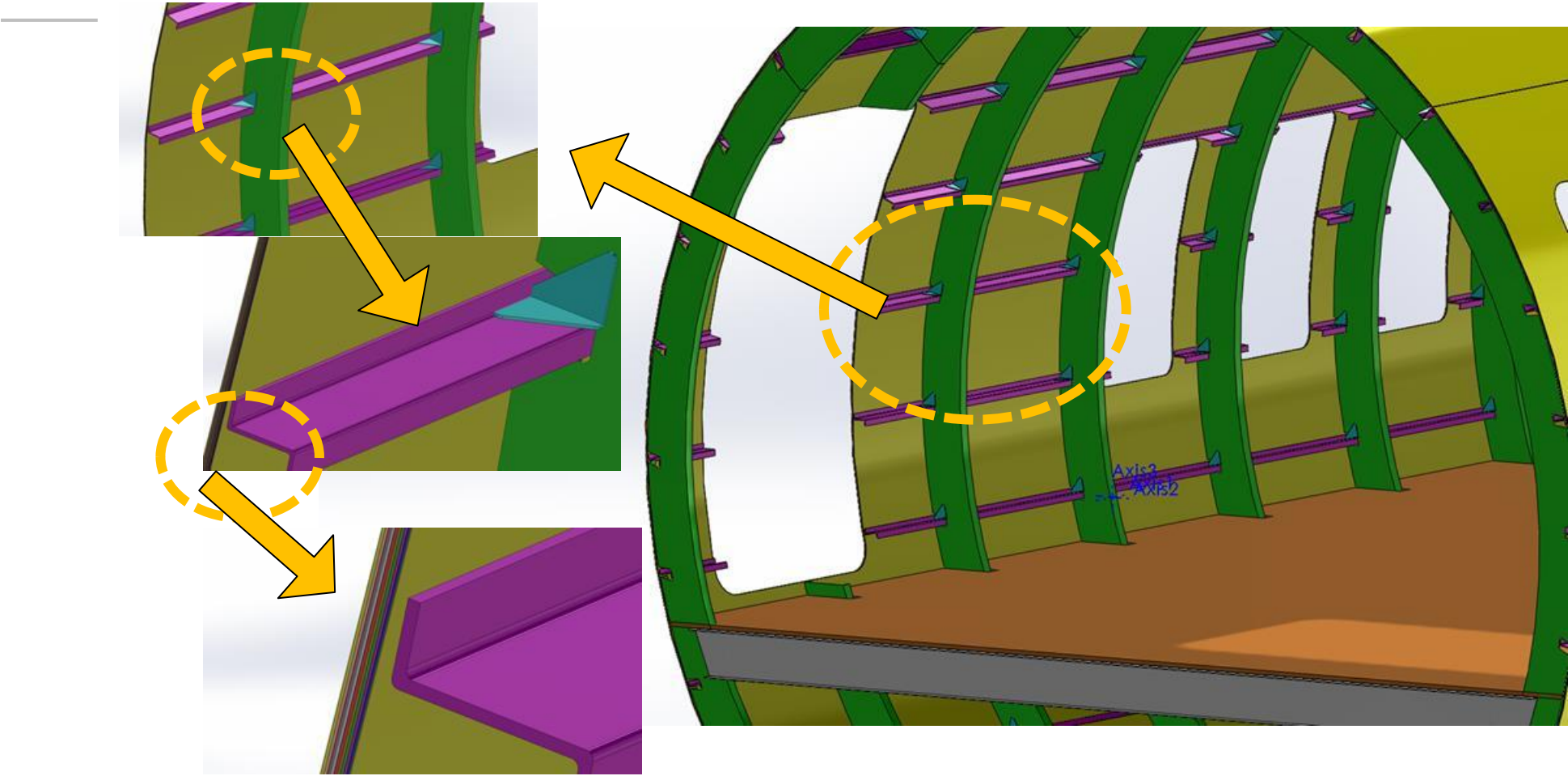



Maintaining Design Intent

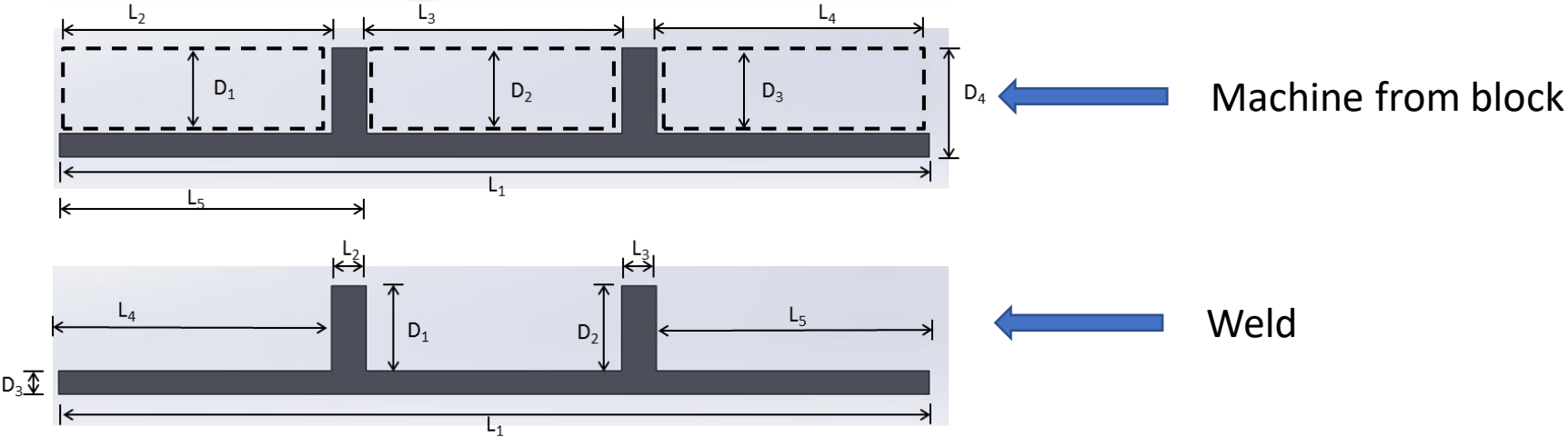
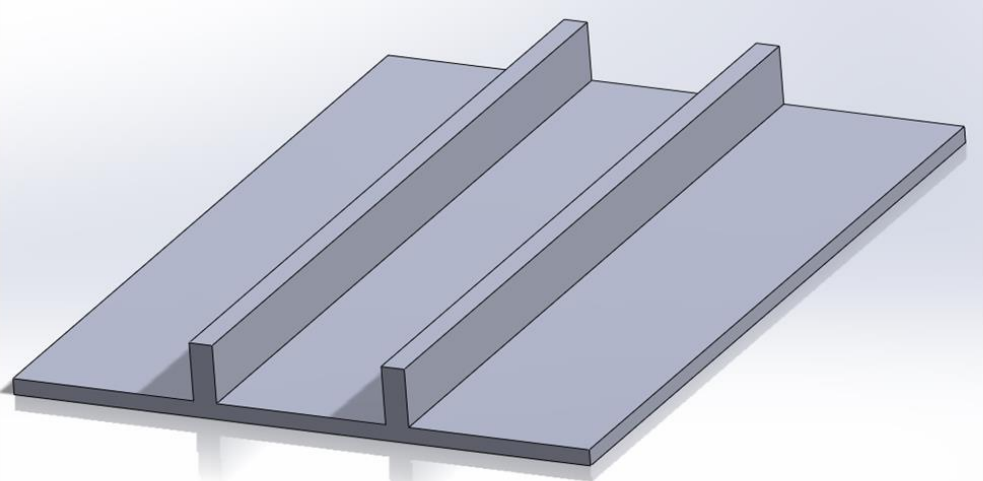

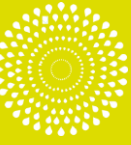

Process is sequential and information leaks away

Regulations

Complexity

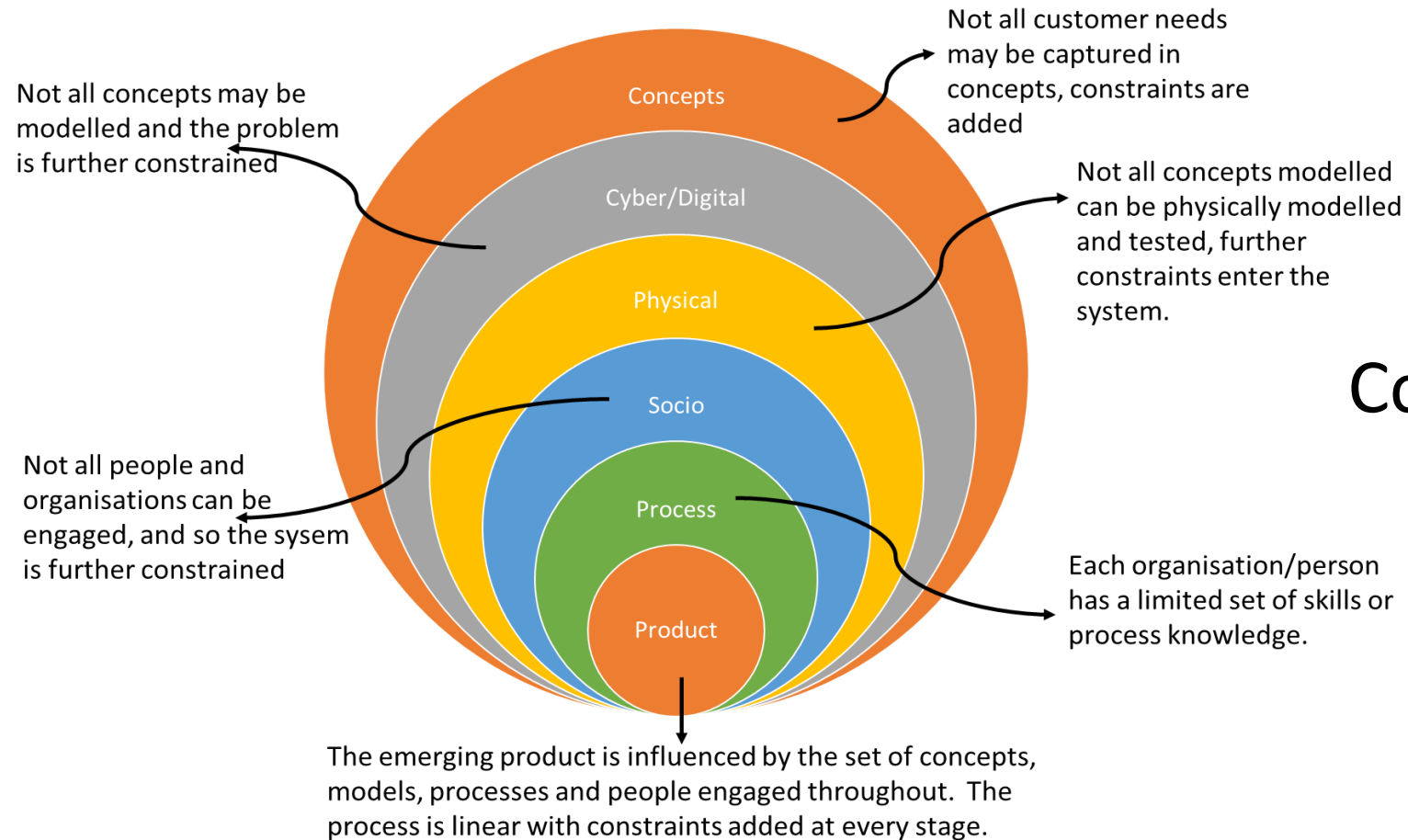

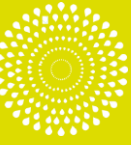

Ontology map – mind blowing!

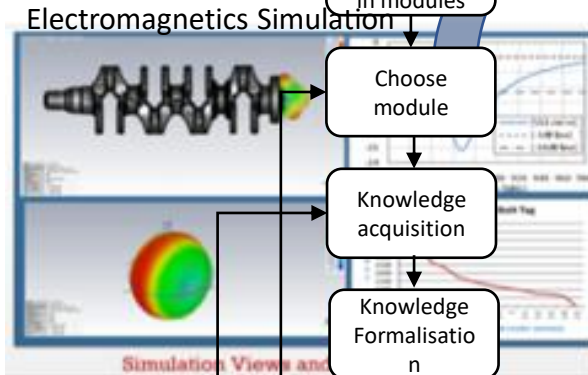
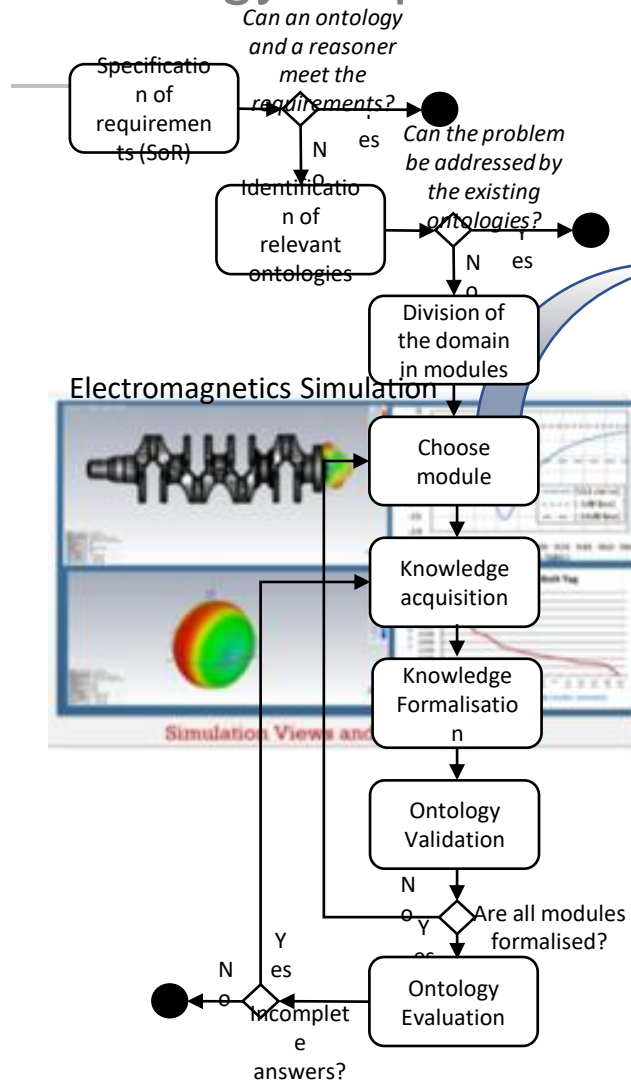

CPS-P Knowledge Interoperability

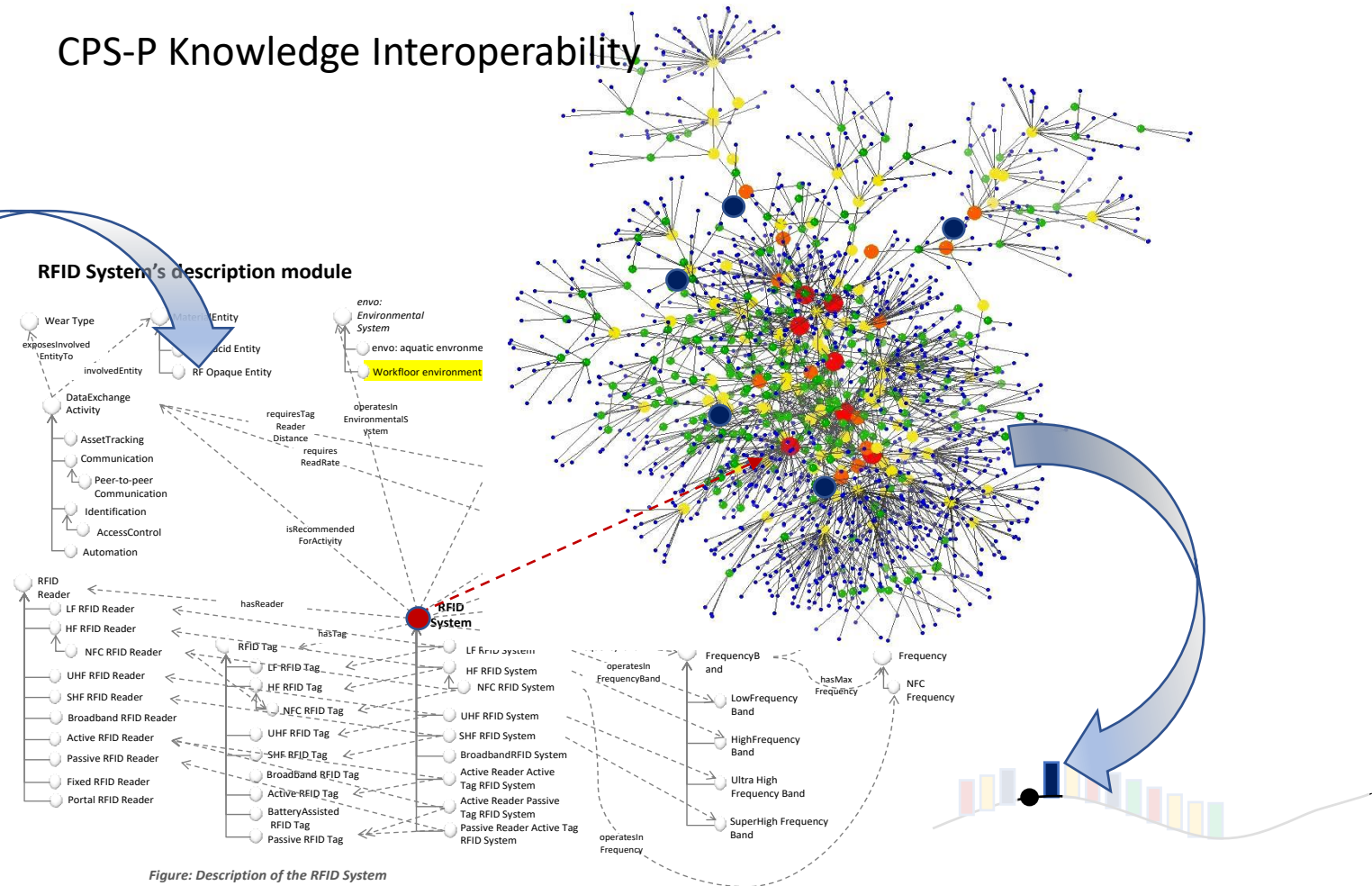
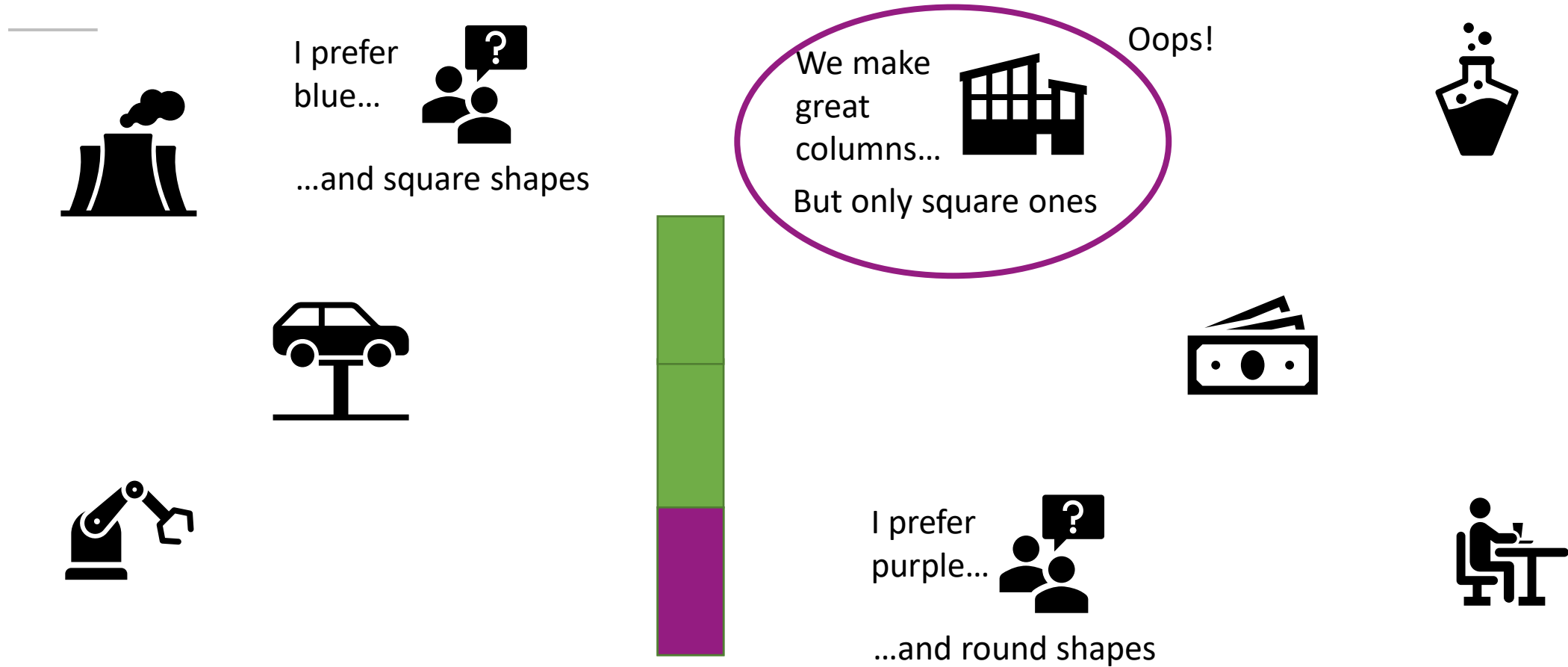

Figure: Description of the RFID System



It gets even more complicated when we think of the wider system!



Objectives are often conflicting

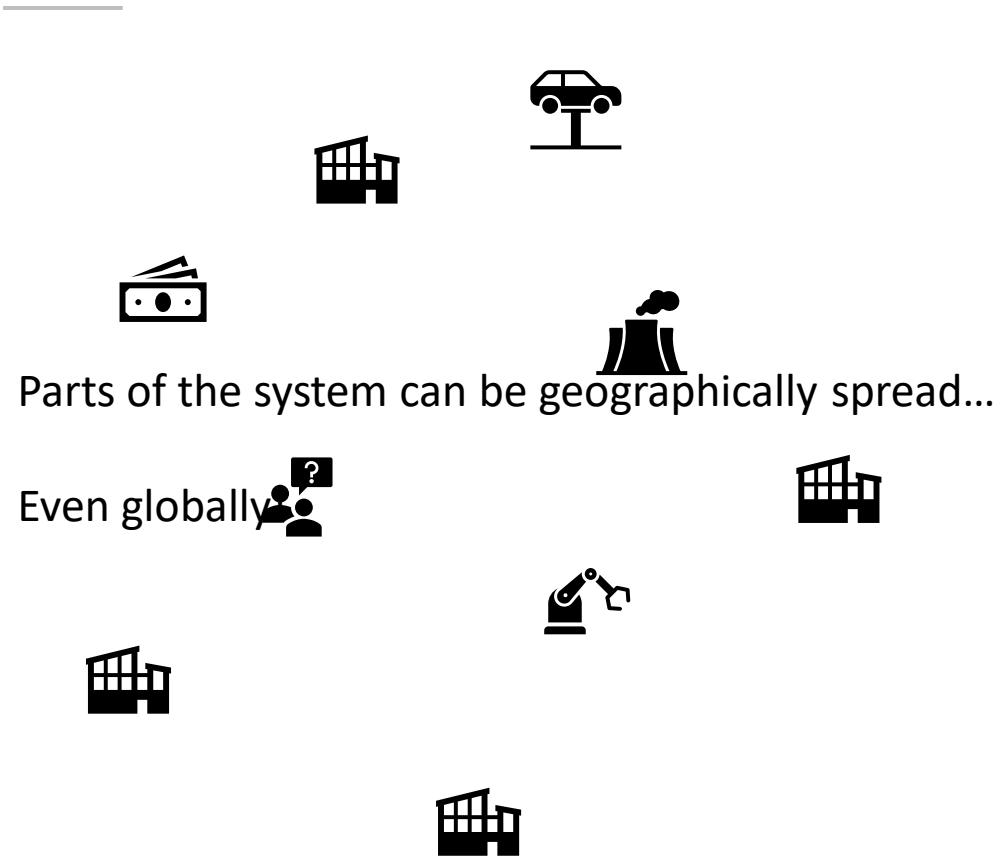



Research Challenges

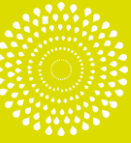

Research Challenges

- **Interoperability – CPS Design Theory**
 - How can we generate ideas and concepts rapidly such that artefacts are designed concurrently with manufacturing systems to create resilient extended enterprises with open communication throughout the whole system?
- **The Cyber World – CPS Modelling Design & Manufacture**
 - How can we represent concepts virtually such that key design characteristics driving intended behaviour are understood, coded and realised via robust, intelligently manufactured product variants?
- **The Physical World – CPS Concept to Reality**
 - What verification and validation concepts are needed to find the shortest and most beneficial pathway to physical realisation aided by a cyber-physical-socio manufacturing ecosystem?
- **The Socio World – CPS The Extended Manufacturing Enterprise**
 - How can we translate and exploit concepts in new organisational structures within a cyber-physical-socio ecosystem to accelerate evolution of design solutions across extended enterprises?

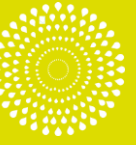

CONCEPT AND ETHOS

- Rethink design rules and processes
- Create new autonomous design processes
- Radically change roles and activities in the manufacturing organisation
- Embrace emergent behaviour for design innovation

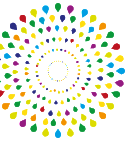

Inspiration from Nature

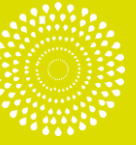

CONCEPT AND ETHOS

—

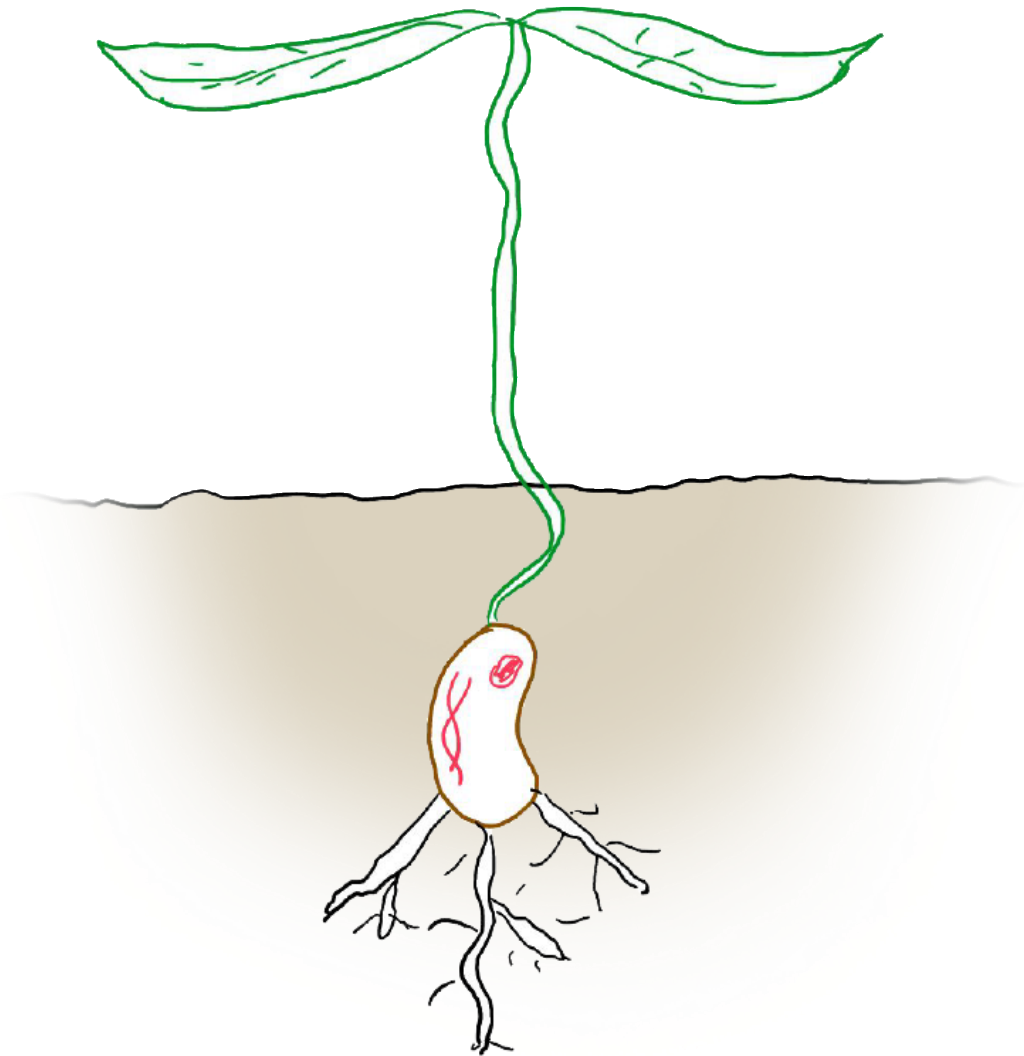

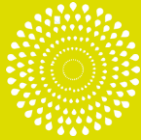

Building Complex Systems – Nature’s Approach

—

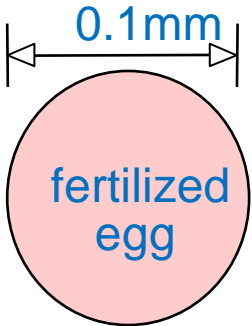
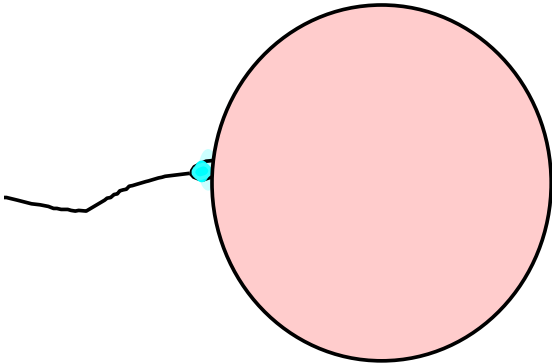

1/2 hour, 1 cell

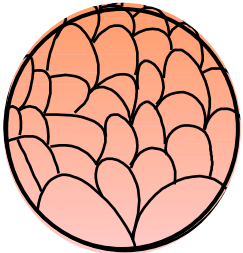

3 hours, 64 cells

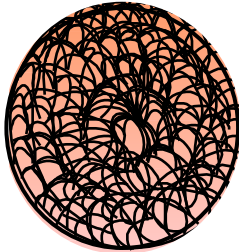

6 hours, 10'000 cells

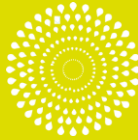

Building Complex Systems – Nature’s Approach

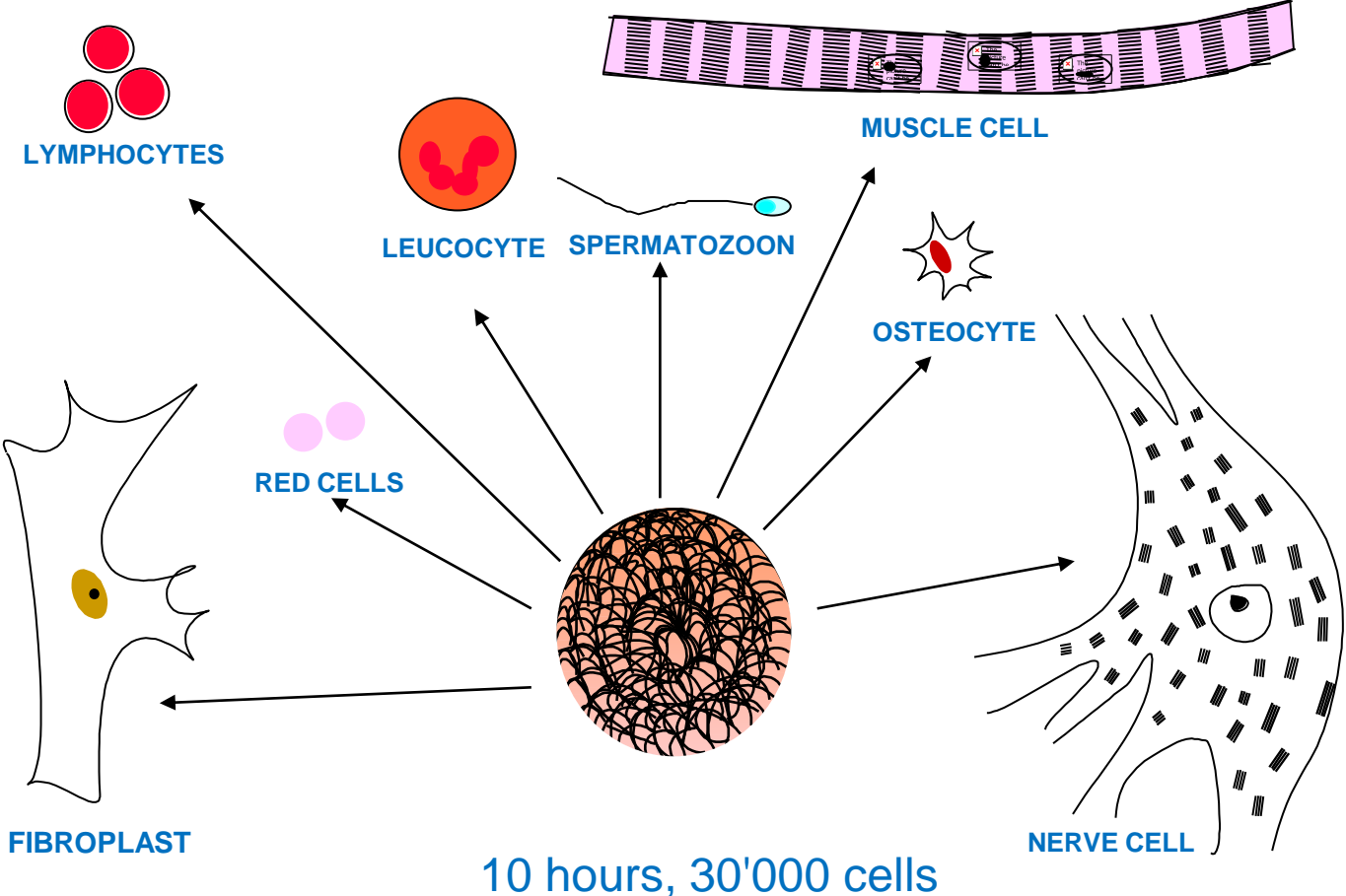

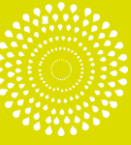

GENOTYPE

CGTTGGAACCGTGTGCCAGTGTGG
AACCGGAAGGGACGTGGTTTTGTTG

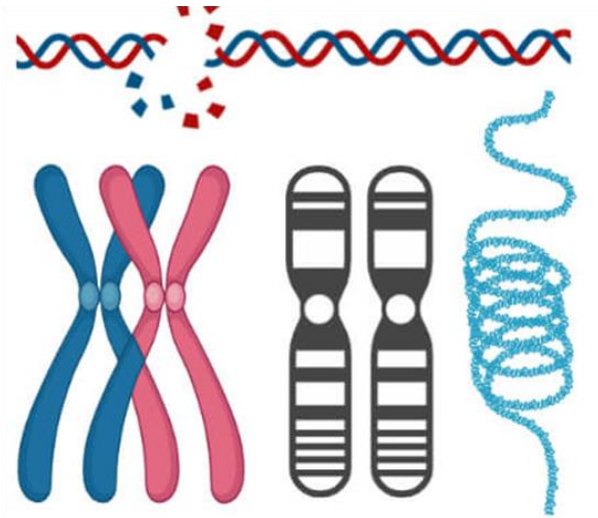

0111001100110101011010101
1010110111011000110010101
0011100110010101101101100
011001100101010101100

DEVELOPMENT

EVOLUTION

MUTATION

SELECTION

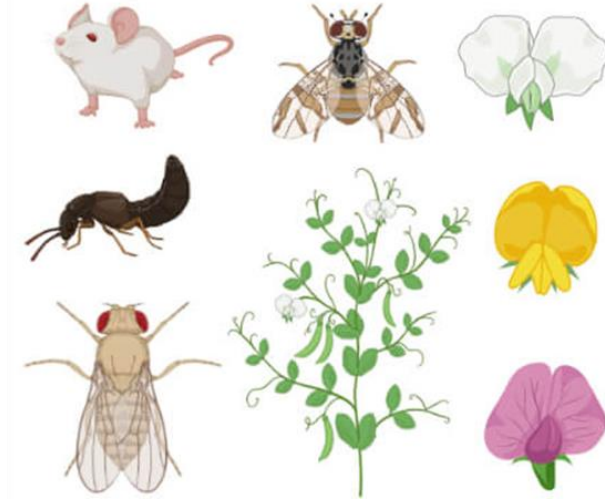

PHENOTYPE

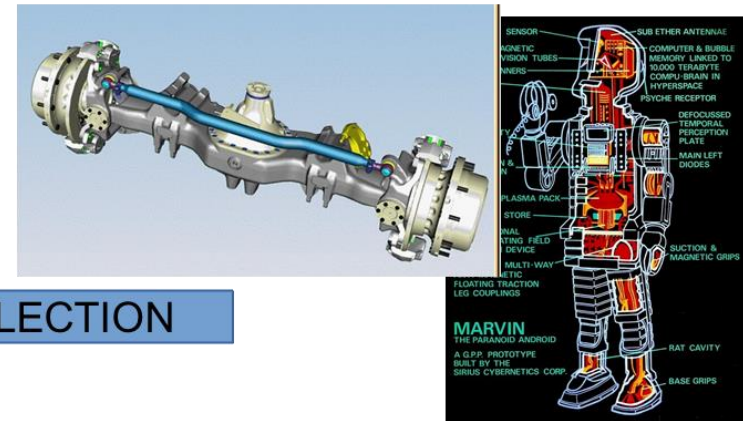



Analogy for biological development

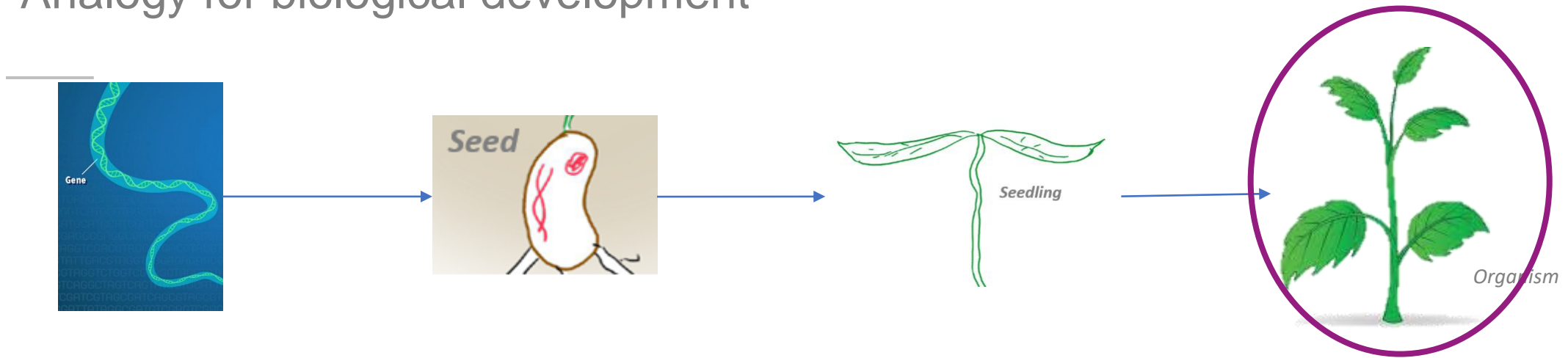

```
length 100 1 100 200 1
random 2.1 1 50 400 2
radius 0.5 1 100 200 1
divide 1 1 100 200 1
bud 1 1 100 200 1
tilt_r 0.0 1 100 200 1
tilt_l 0.0 1 100 200 1
xbar_h 0.0 1 100 200 1
ybar_h 0.0 1 100 200 1
cross_section 0.0 1 100 200 1
square 0.0 1 100 200 1
a 10.0 1 100 200 1
square 1 1 100 200 1
cross_section 0.0 1 100 200 1
stress_sensor 0.0 1 100 200 1
stress_receptor 0.0 1 100 200 1
stress 0.0 1 100 200 1
range 120.0 1 0 200 1
range 140.0 1 200 400 1
range 160.0 1 400 600 1
stress 0.0 1 100 200 1
stress_receptor 0.0 1 100 200 1
stress_converter 20.0 1 100 200 1
stress_sensor 0.0 1 100 200 1
support_sensor 0.0 1 100 200 1
support_receptor 0.0 1 100 200 1
support 0.0 1 100 200 1
range 50.0 1 0 150 1
range 100.0 1 150 300 1
range 150.0 1 300 450 1
range 175.0 1 450 600 1
support 0.0 1 450 600 1
support_receptor 0.0 1 100 200 1
support_converter 20.0 1 0 200 1
support_sensor 0.0 1 100 200 1
material 0.0 1 100 200 1
type 0.0 1 100 200 1
steel 0.0 1 100 200 10
type 0.0 1 100 200 1
parameters 0.0 1 100 200 1
```

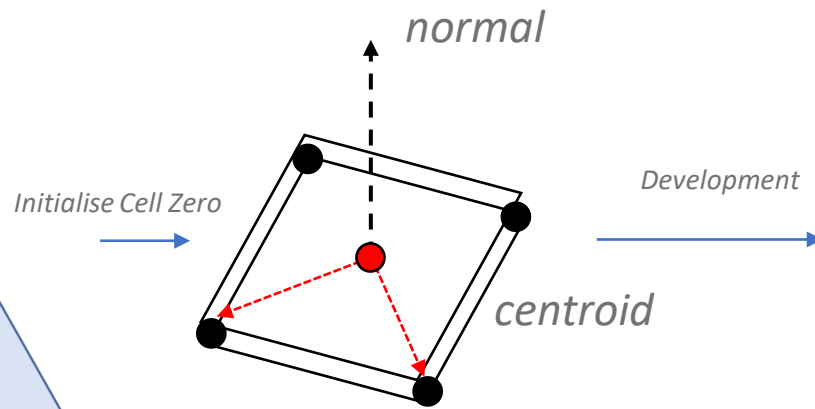
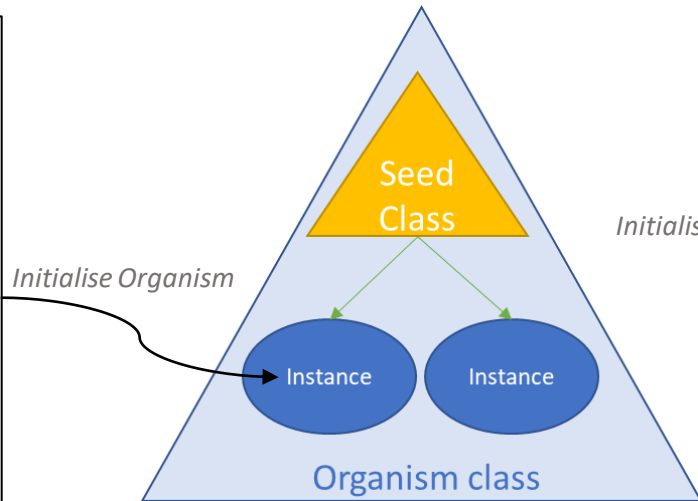

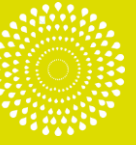

Interacting with the environment produces many solutions...

—

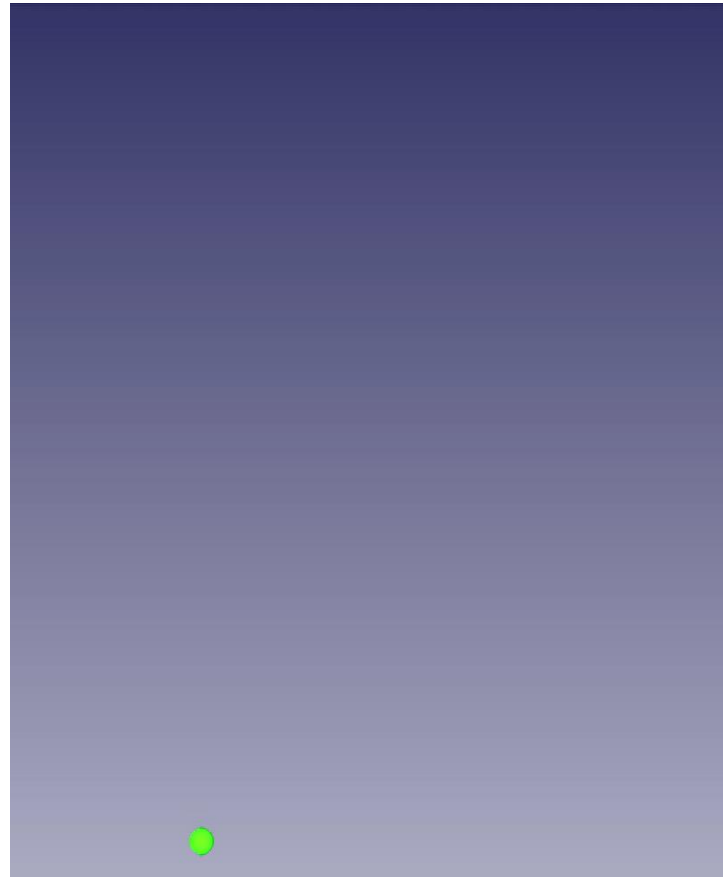
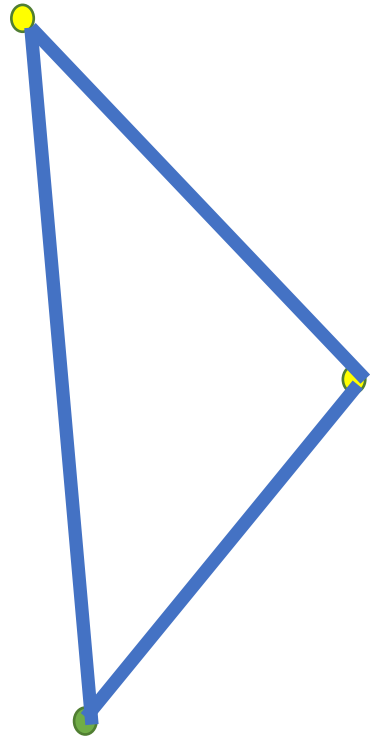



Creating variation & innovation

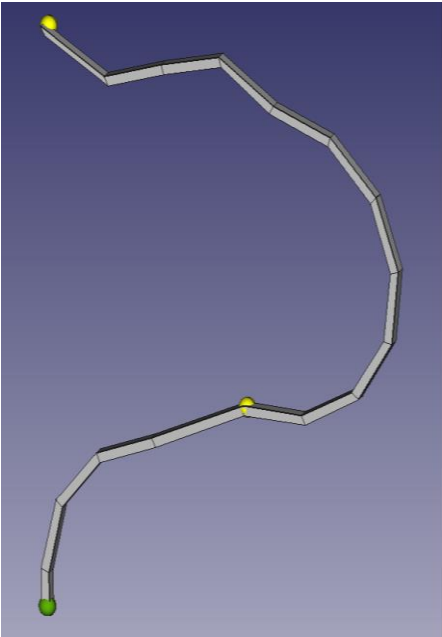

MVP1.0 – No Budding
2 Supports – Equal
field strength

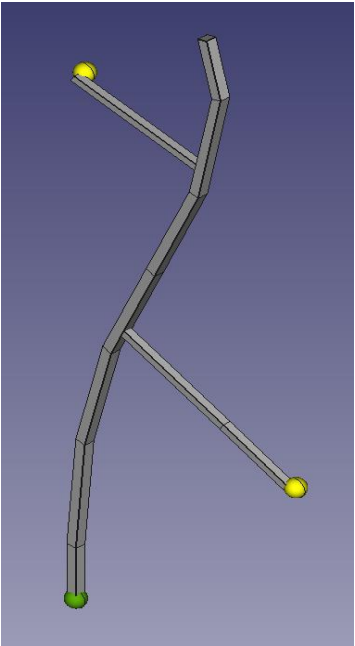

Length - 10

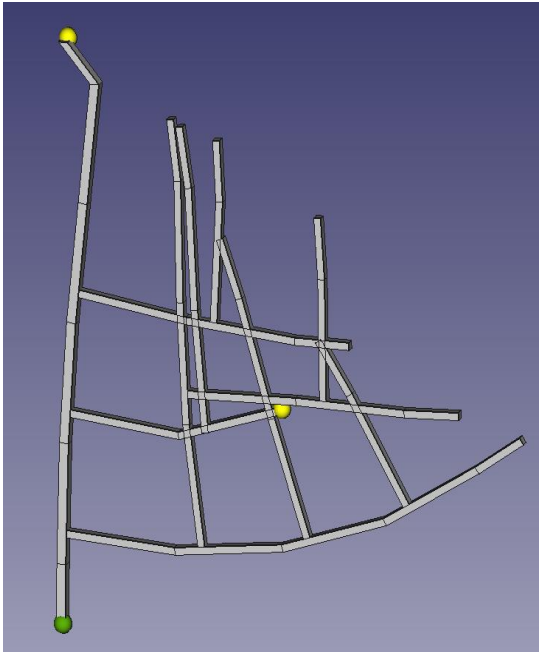
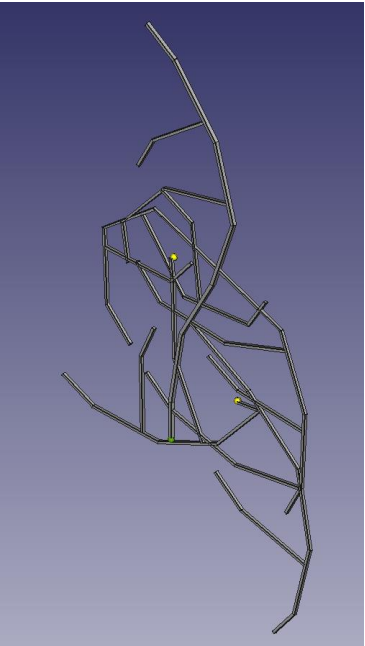

Length - 10
Bud Check - 45
Support Converter - 5

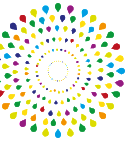

Interoperability

Re-Imagining Engineering Design

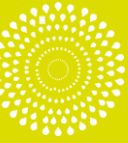

The process is very, very complex...

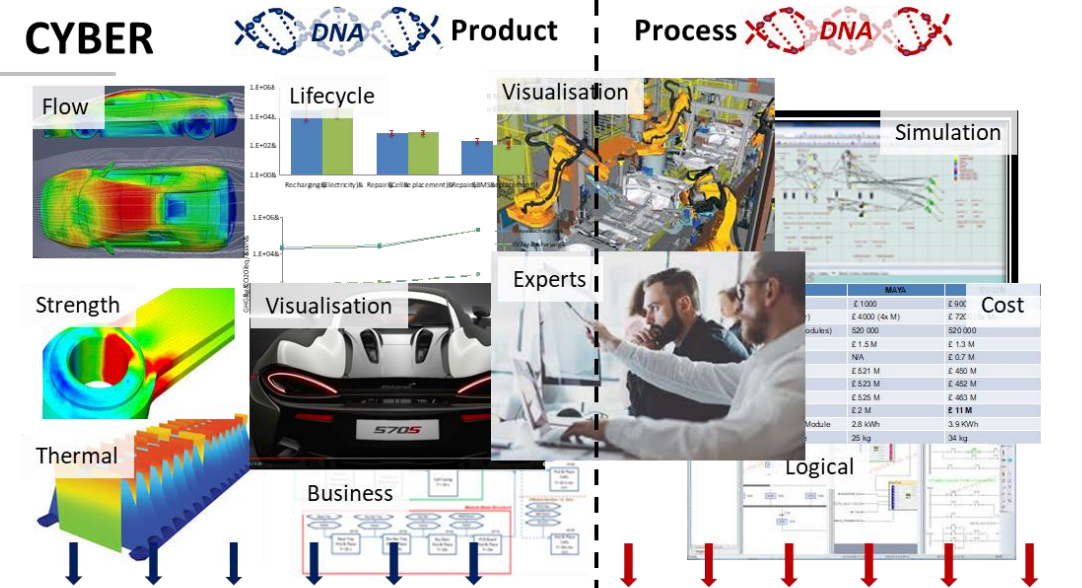

Cyber Physical Social Systems (CPSS): Interoperable CONCEPT BUS

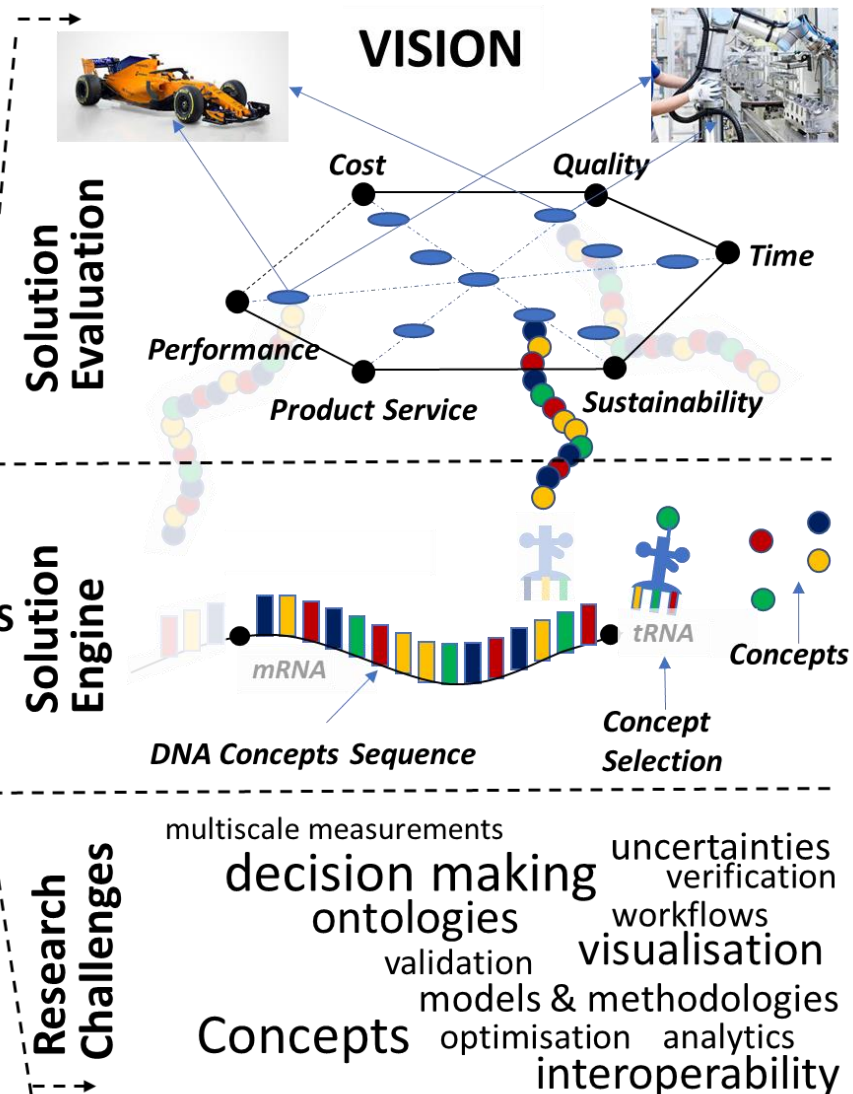
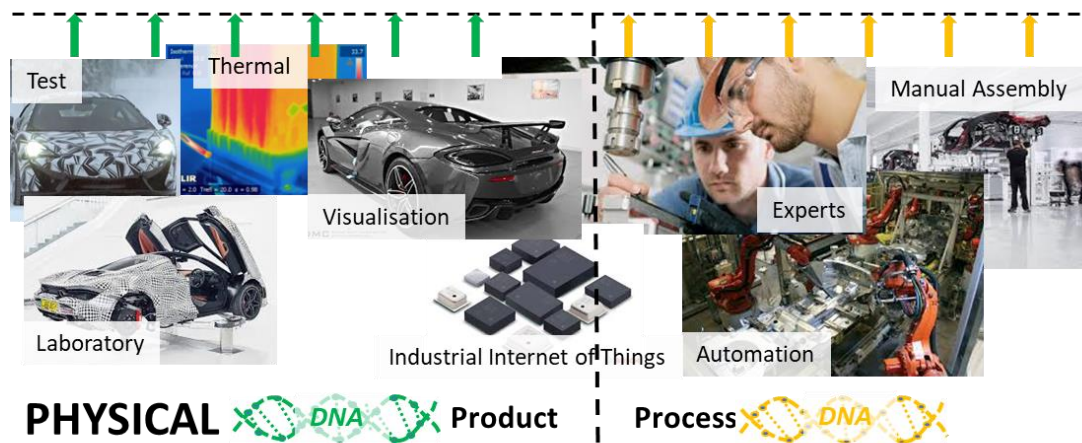

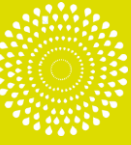

Analogy for biological development

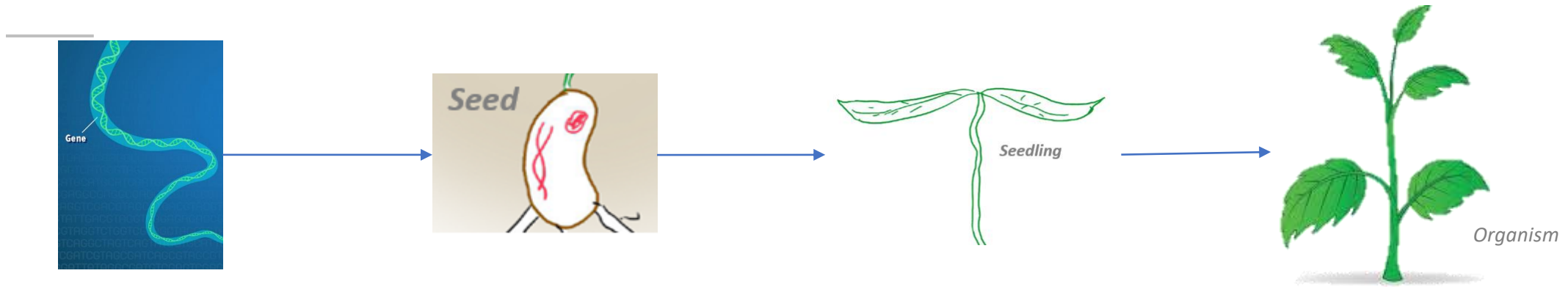

```
length 100 1 100 200 1
random 2.1 1 50 400 2
radius 0.5 1 100 200 1
divide 1 1 100 200 1
bud 1 1 100 200 1
tilt_r 0.0 1 100 200 1
tilt_l 0.0 1 100 200 1
xbar_h 0.0 1 100 200 1
ybar_h 0.0 1 100 200 1
cross_section 0.0 1 100 200 1
square 0.0 1 100 200 1
a 10.0 1 100 200 1
square 1 1 100 200 1
cross_section 0.0 1 100 200 1
stress_sensor 0.0 1 100 200 1
stress_receptor 0.0 1 100 200 1
stress 0.0 1 100 200 1
range 120.0 1 0 200 1
range 140.0 1 200 400 1
range 160.0 1 400 600 1
stress 0.0 1 100 200 1
stress_receptor 0.0 1 100 200 1
stress_sensor 0.0 1 100 200 1
support_sensor 0.0 1 100 200 1
support_receptor 0.0 1 100 200 1
support 0.0 1 100 200 1
range 50.0 1 0 150 1
range 100.0 1 150 300 1
range 150.0 1 300 450 1
range 175.0 1 450 600 1
support 0.0 1 450 600 1
support_receptor 0.0 1 100 200 1
support_converter 20.0 1 0 200 1
support_sensor 0.0 1 100 200 1
material 0.0 1 100 200 1
type 0.0 1 100 200 1
steel 0.0 1 100 200 10
type 0.0 1 100 200 1
parameters 0.0 1 100 200 1
```

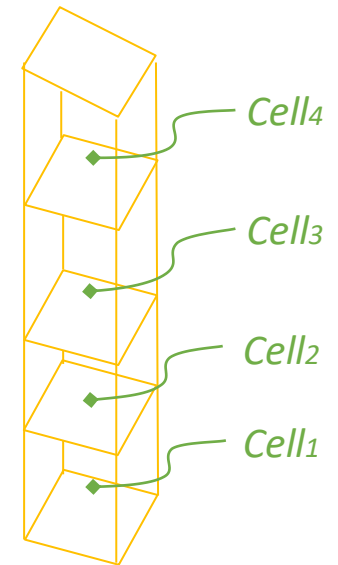
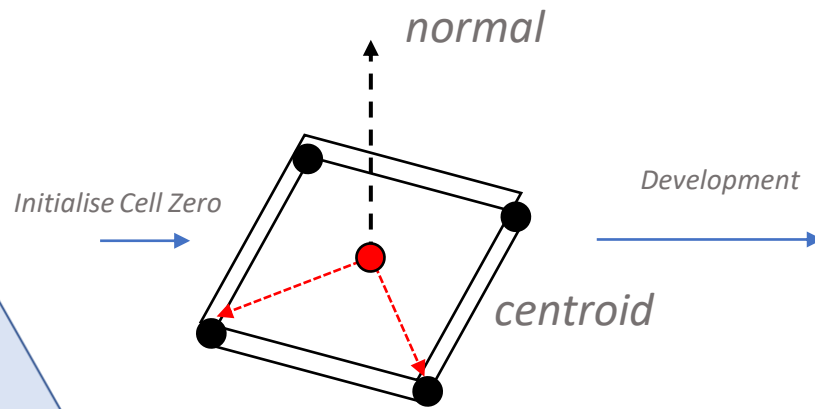
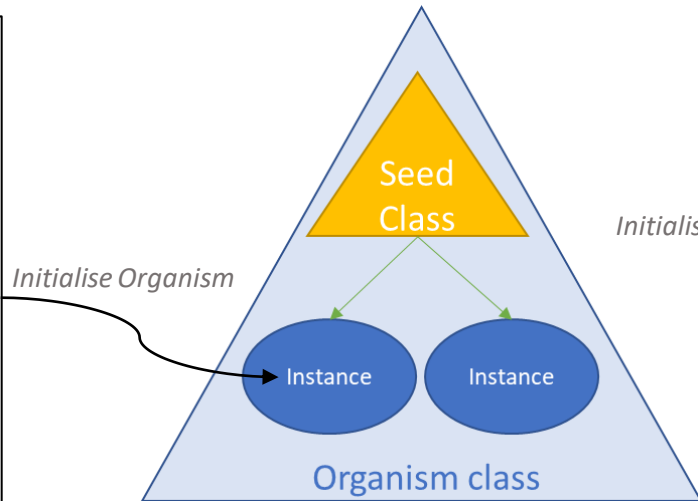

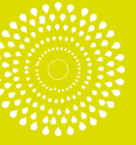

Having dynamic geometry

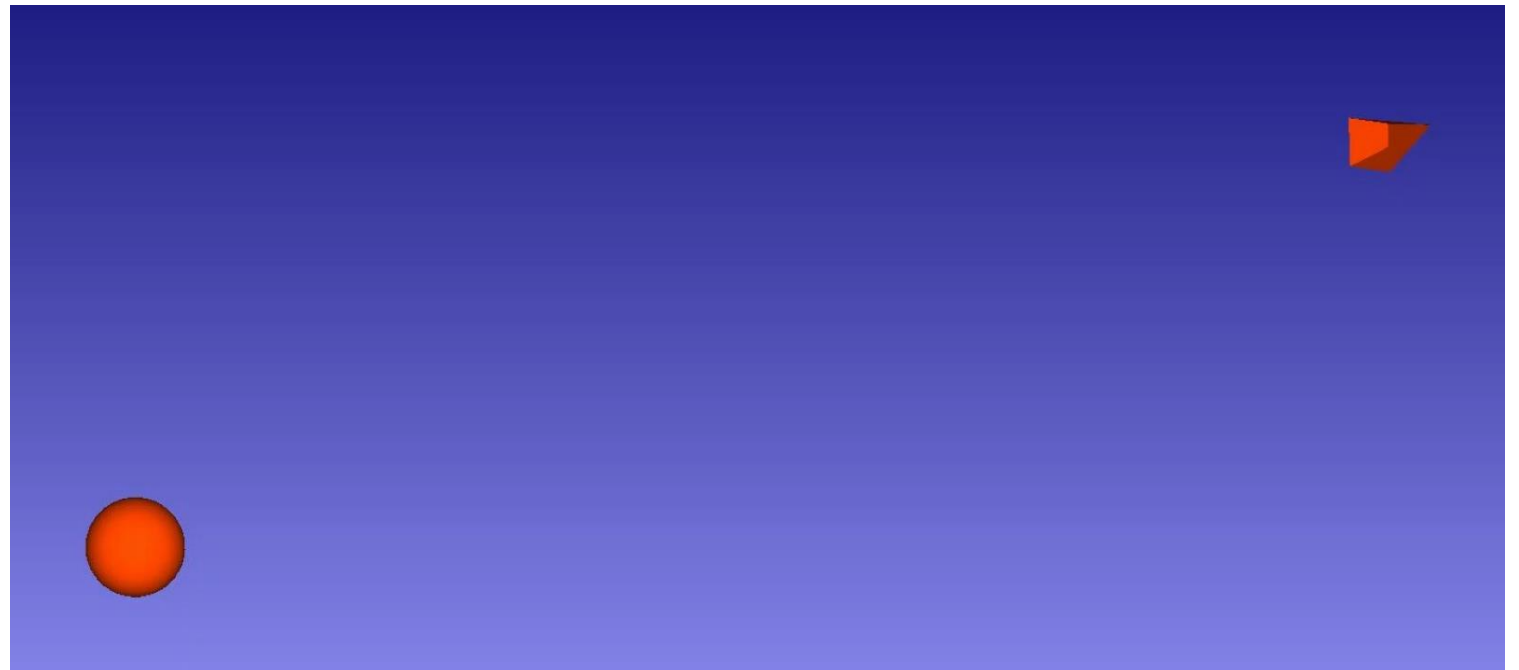
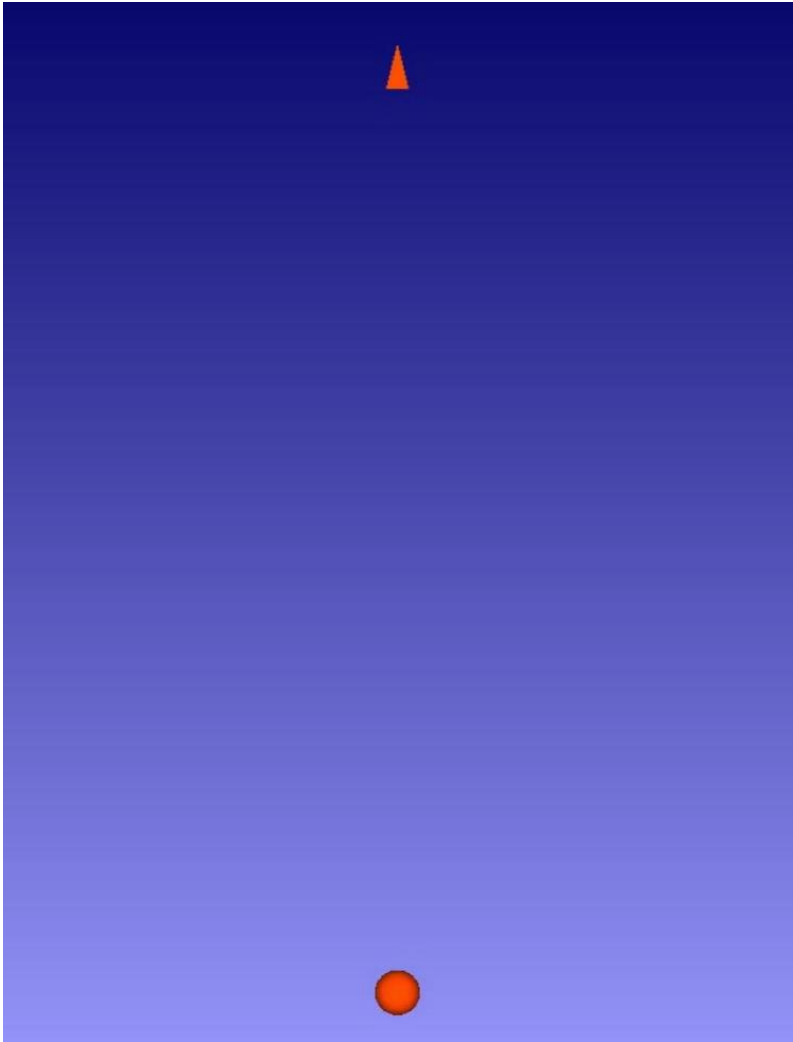

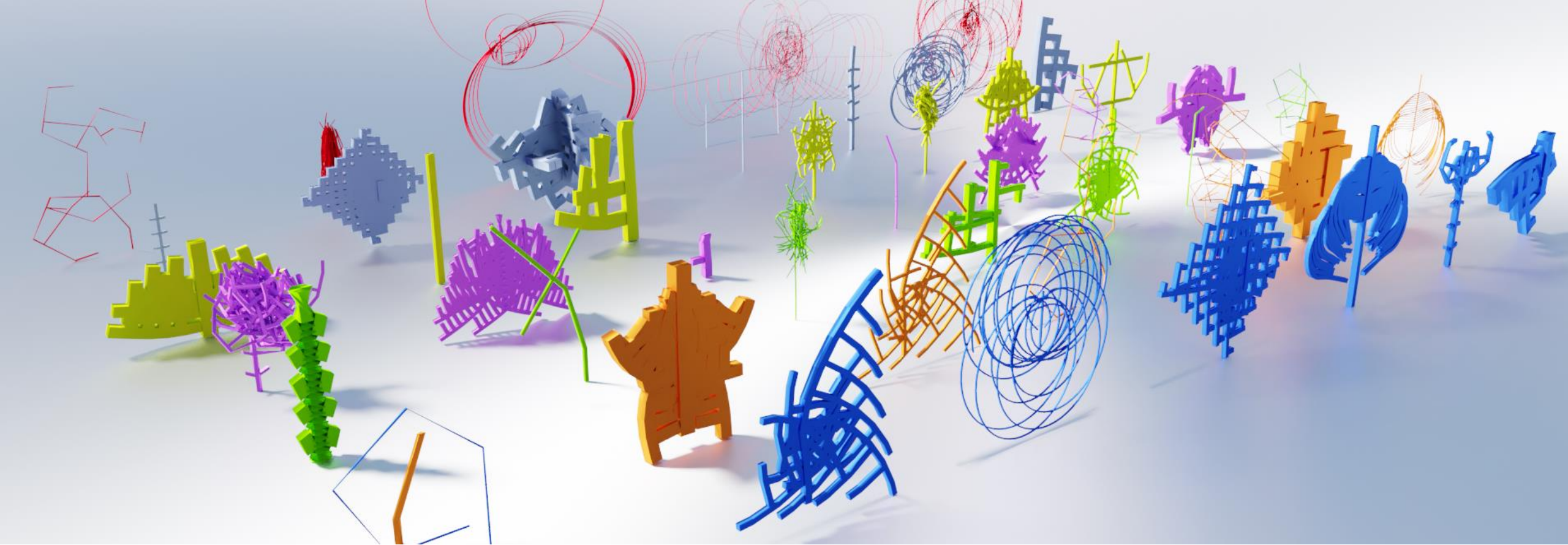

Populations with variation

- Requires ability to grow (develop) in the environment & be sensitive to the environment

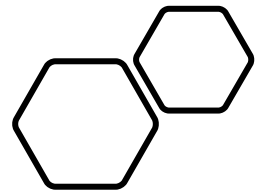

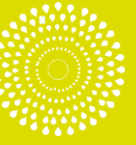

Exploring alternative algorithms...

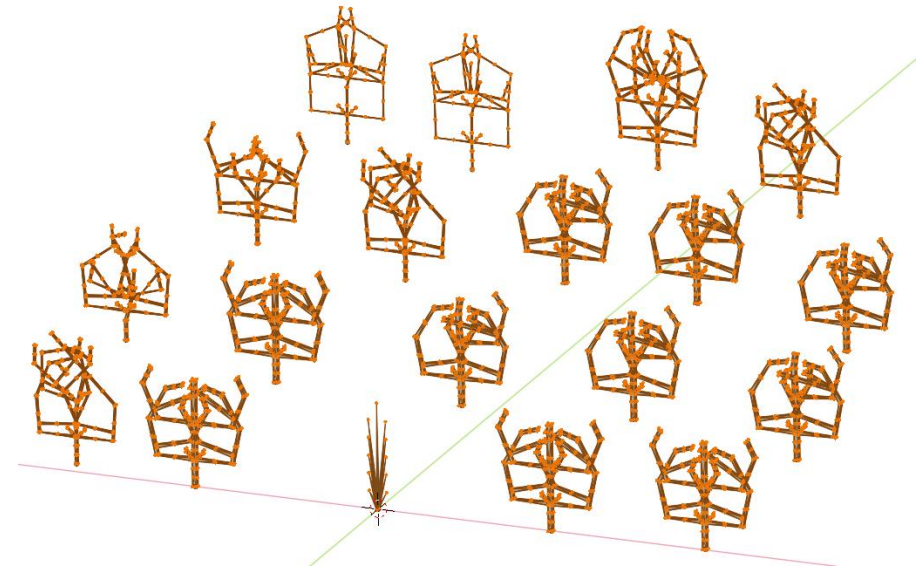
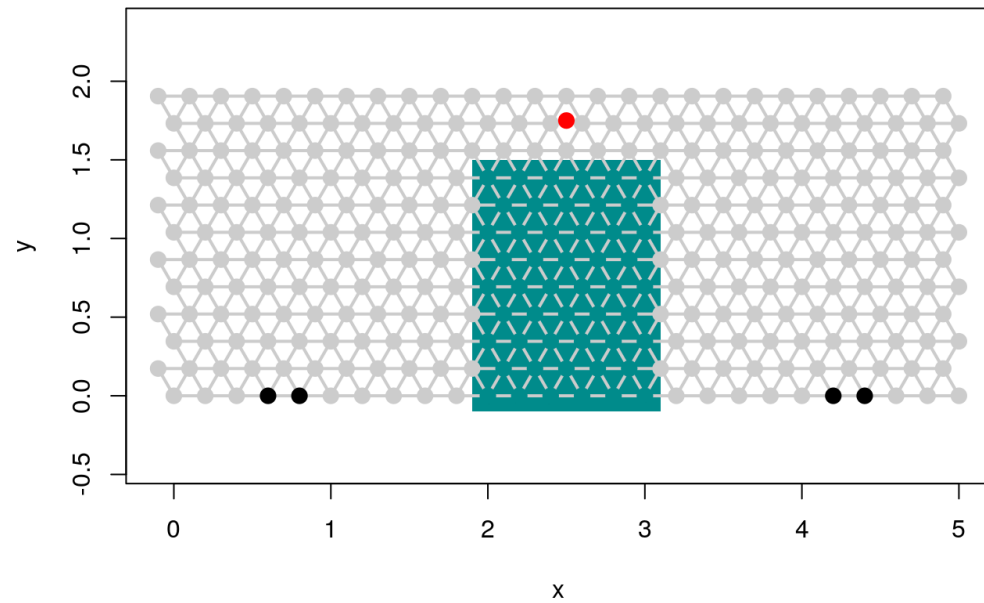

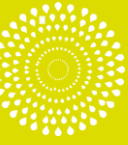

Stage 1: undifferentiated growth



Stage 4: Pruning / merging

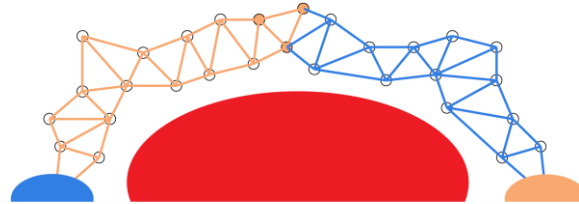

Stage 2: Networks 'sense' each other

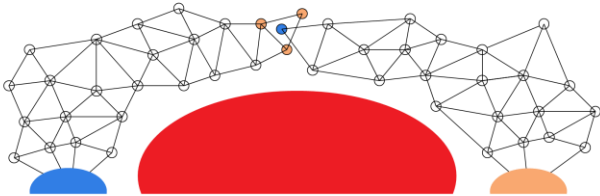

Stage 5: Force alignment I

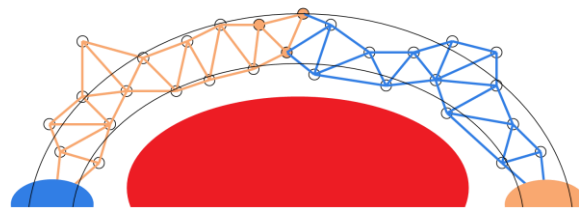

Stage 3: Info diffuses back

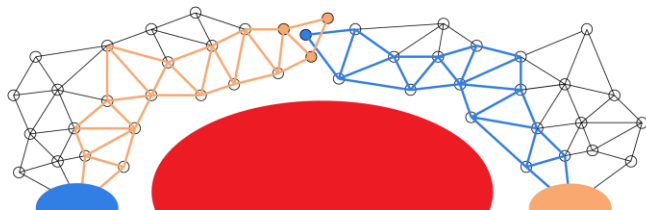

Stage 6: Force alignment II

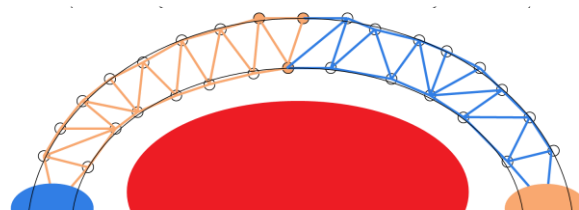

Exploring a range of techniques as appropriate to solve problems!



What are the engineering equivalents for the environment?

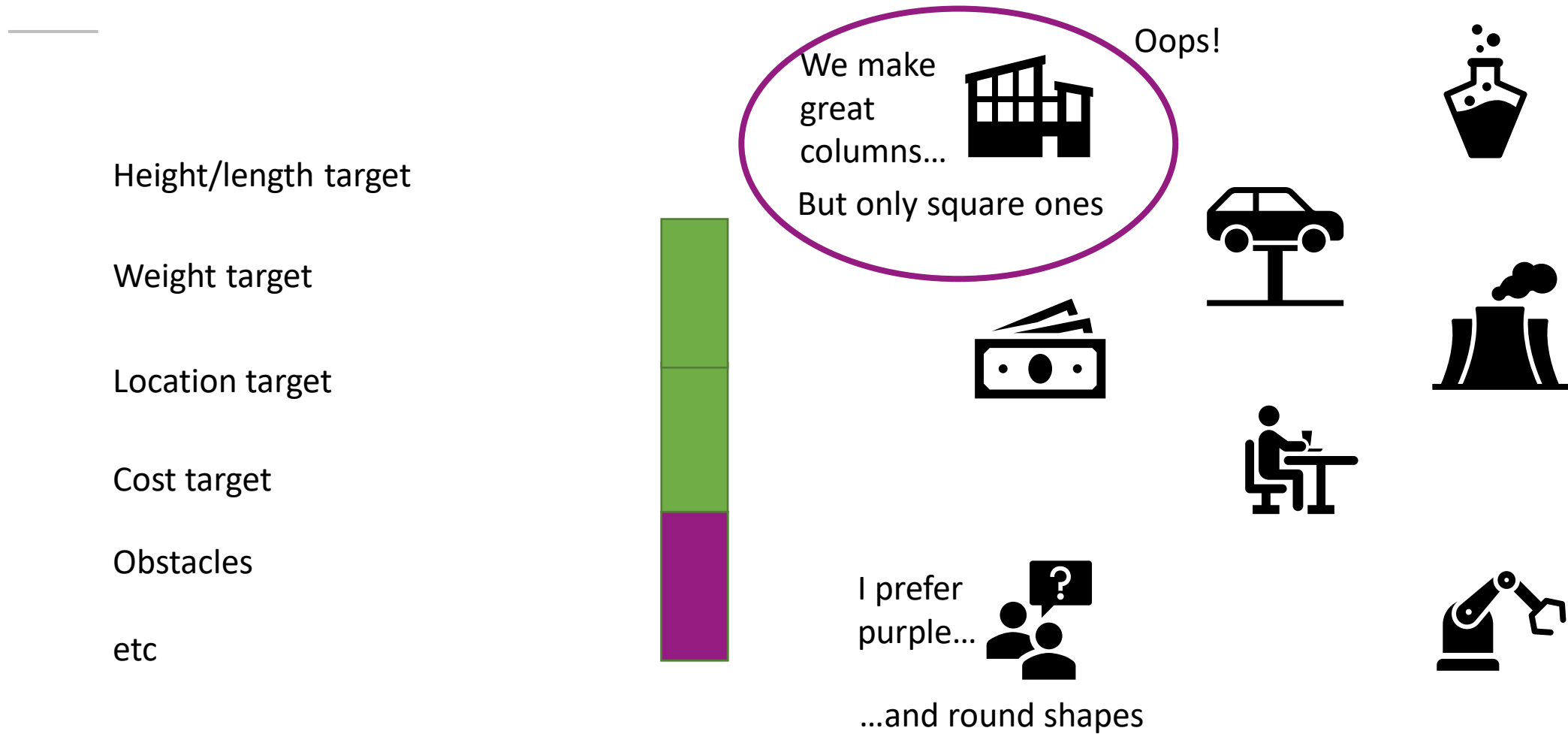

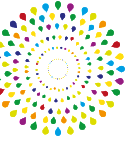

The Cyber World

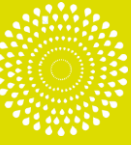

Different actors in the system have different views and models.

Function (Intent) of the stiffener is to carry end load and a little (but preferably no) bending, supporting the skin.

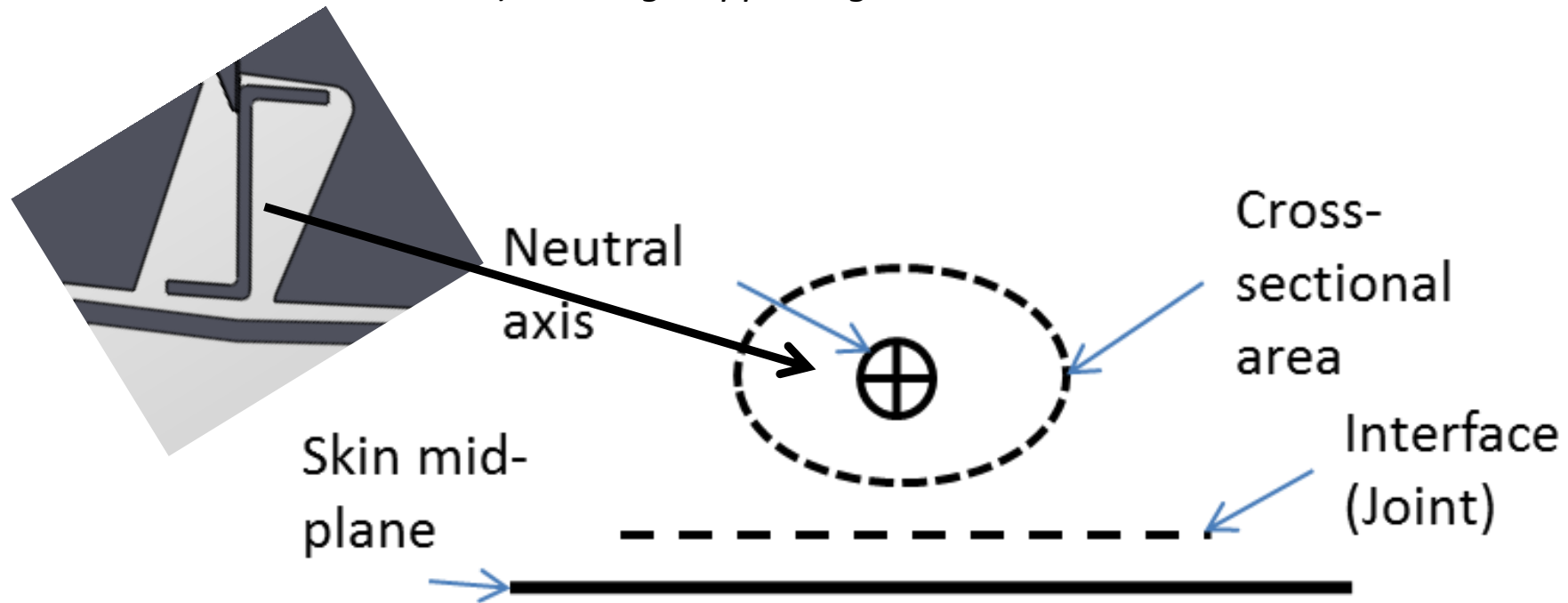



The right representation for the right decision at the right time

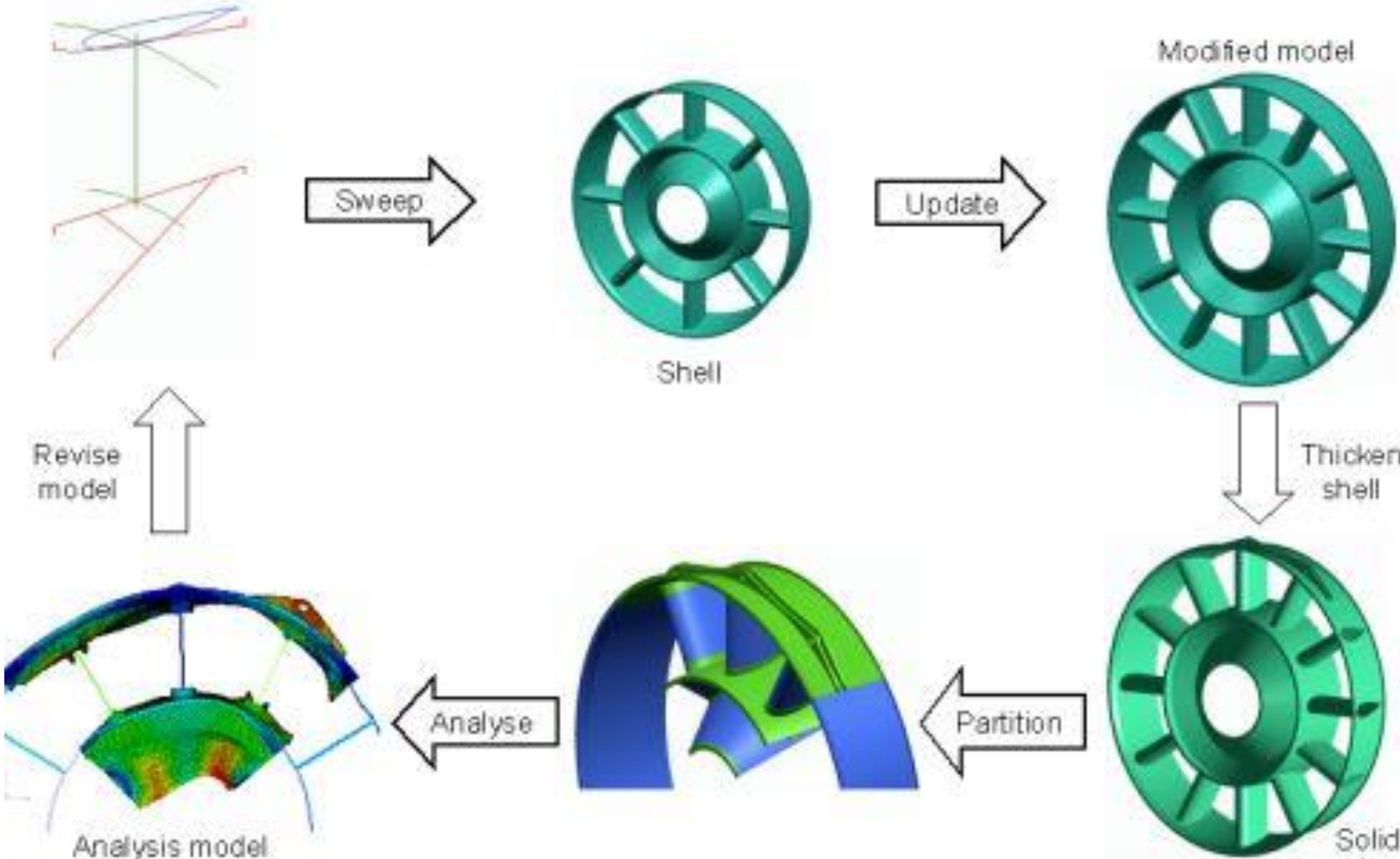

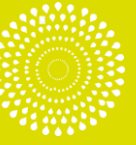

Representing Concepts in Digital Form

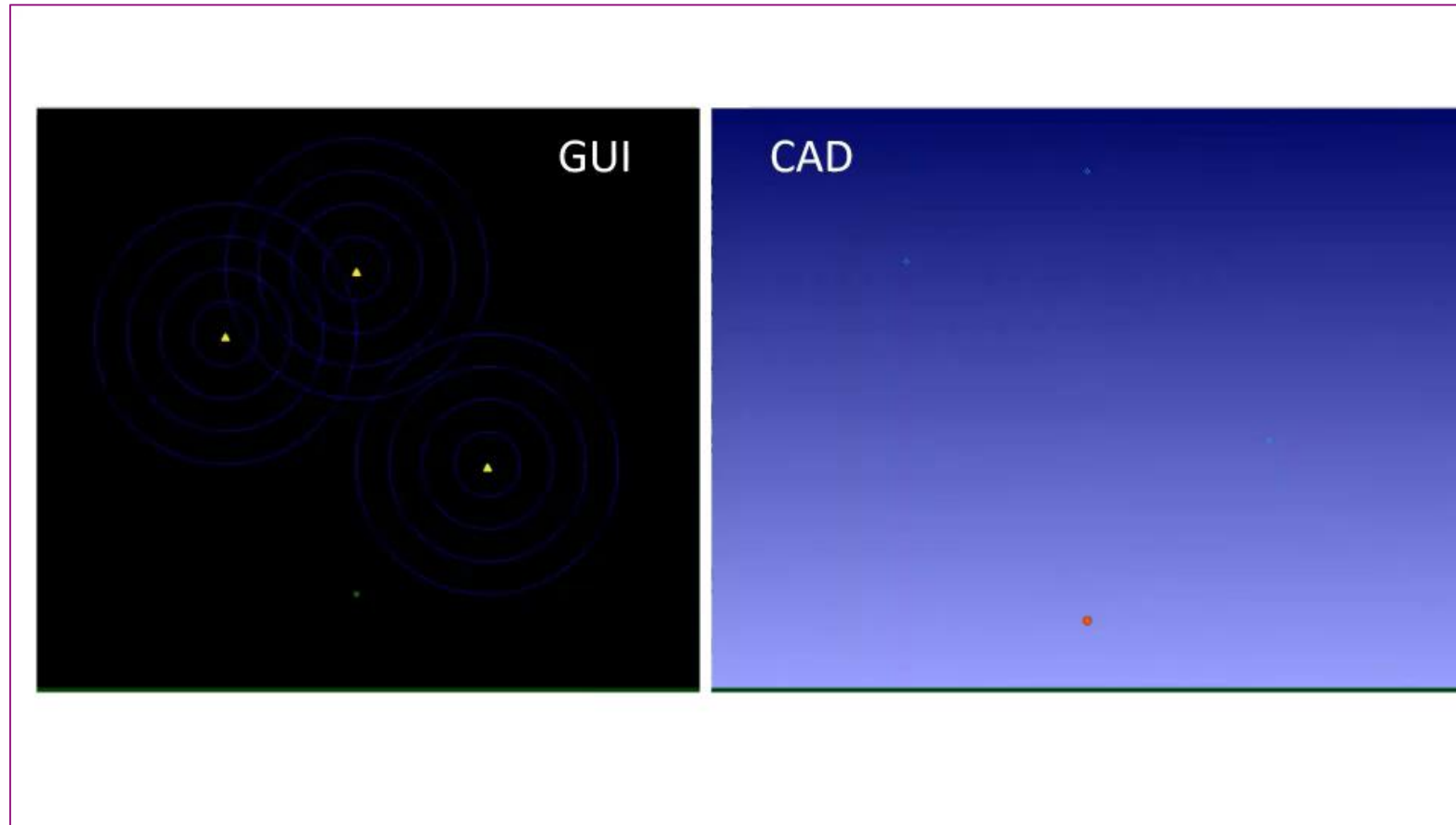



With stresses

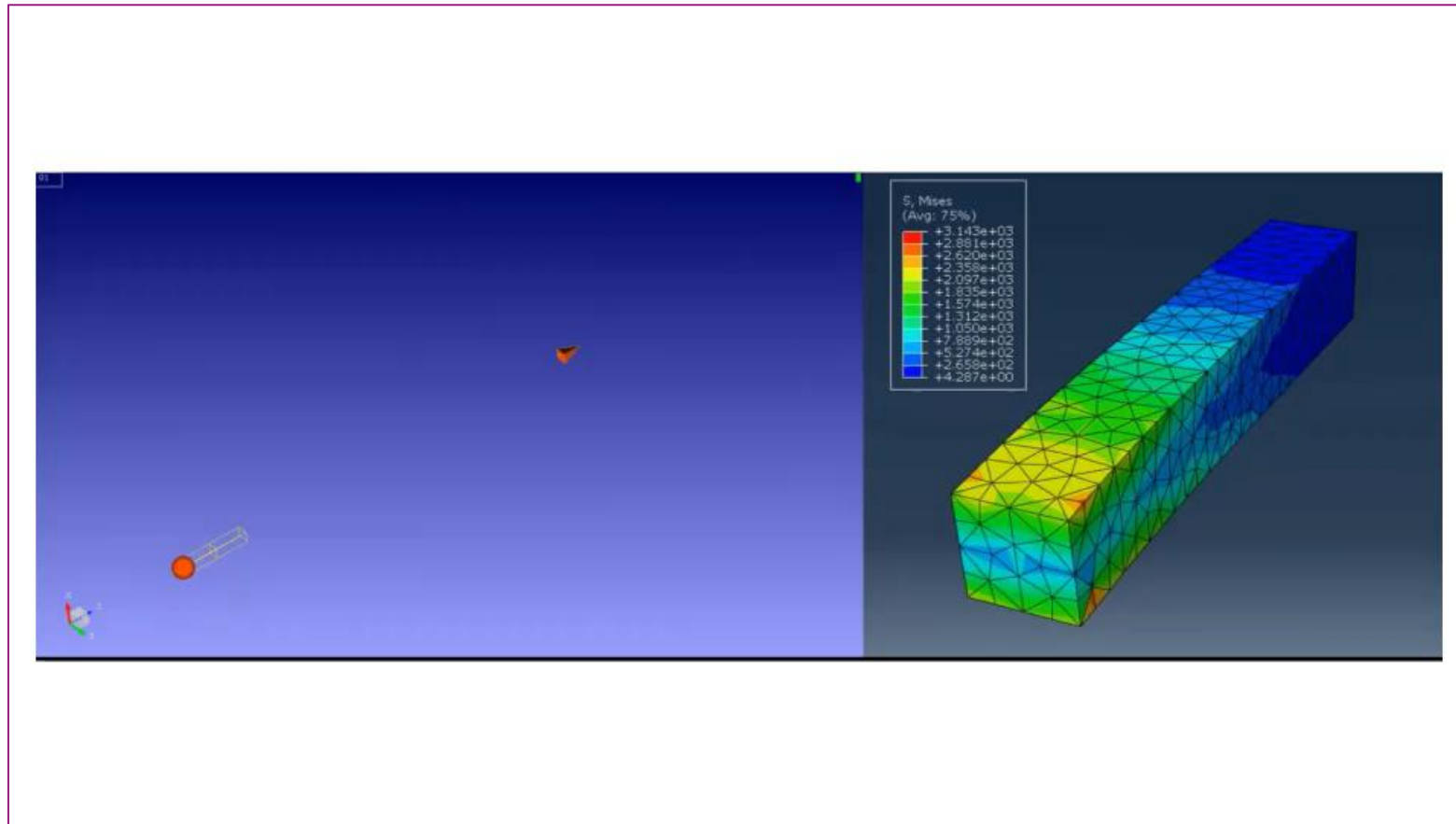

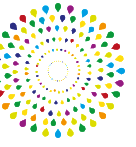

The Physical World

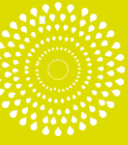

Component Manufacture

- Geometry is different in analysis and manufacturing

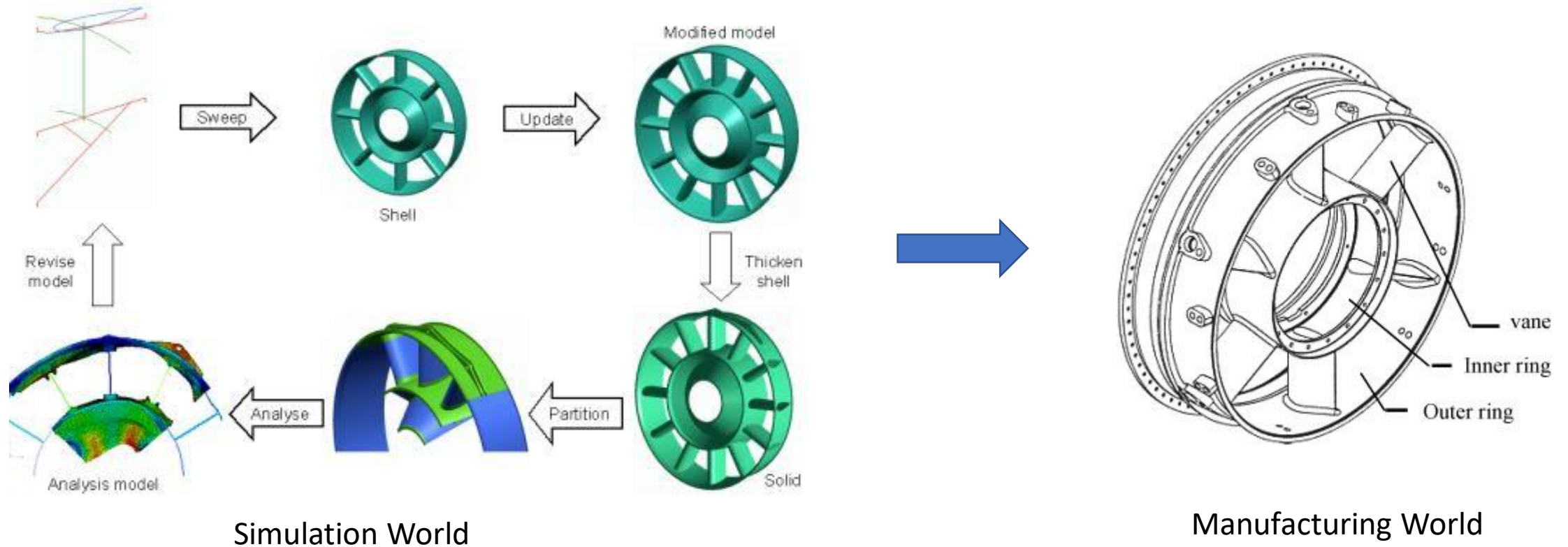

Re-Imagining Engineering Design



Verification and Validation

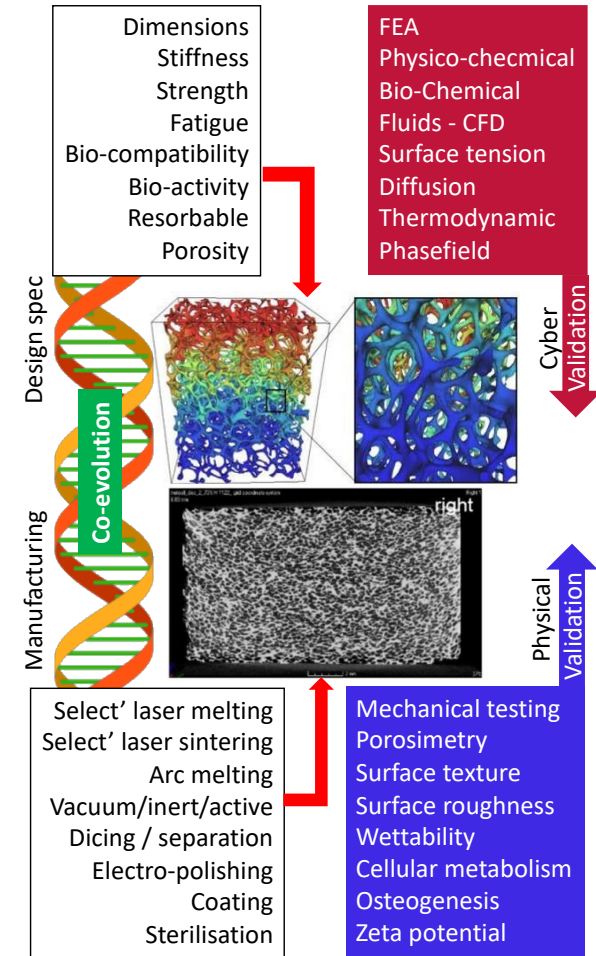
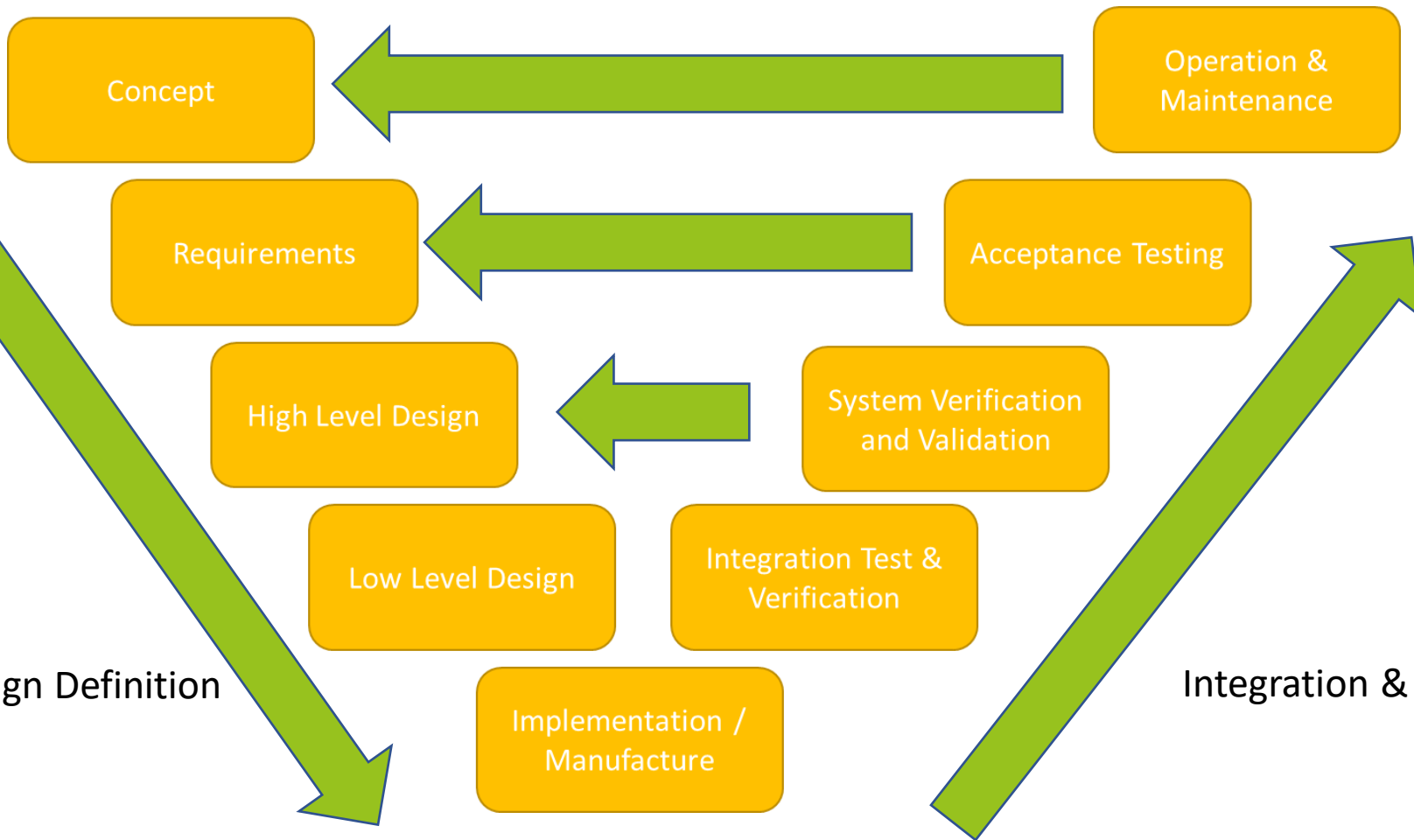

Exemplar demonstrator for Design-to-Prescription application

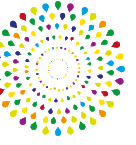

The Socio World

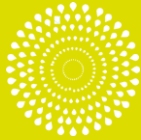

Human in the Loop

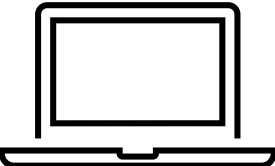
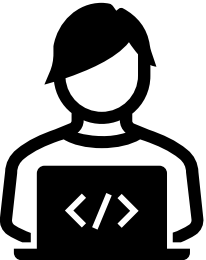
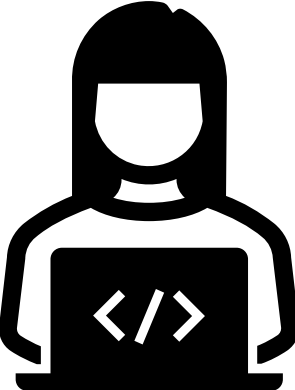
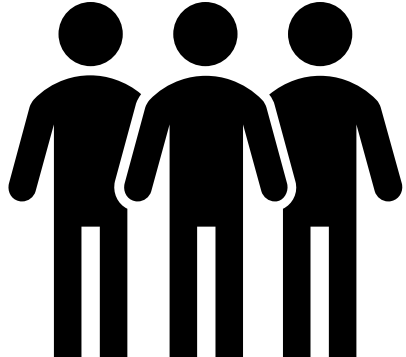
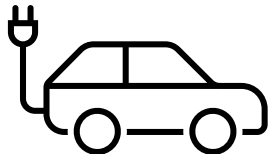
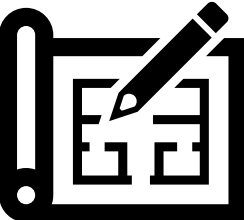
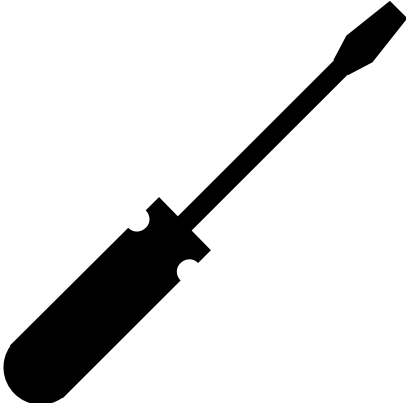
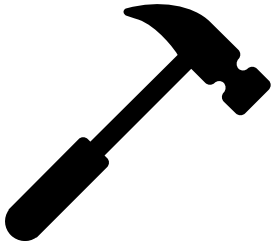
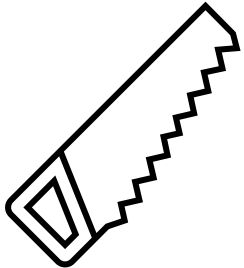

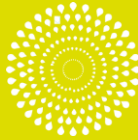

All in concert and perfectly attuned...?

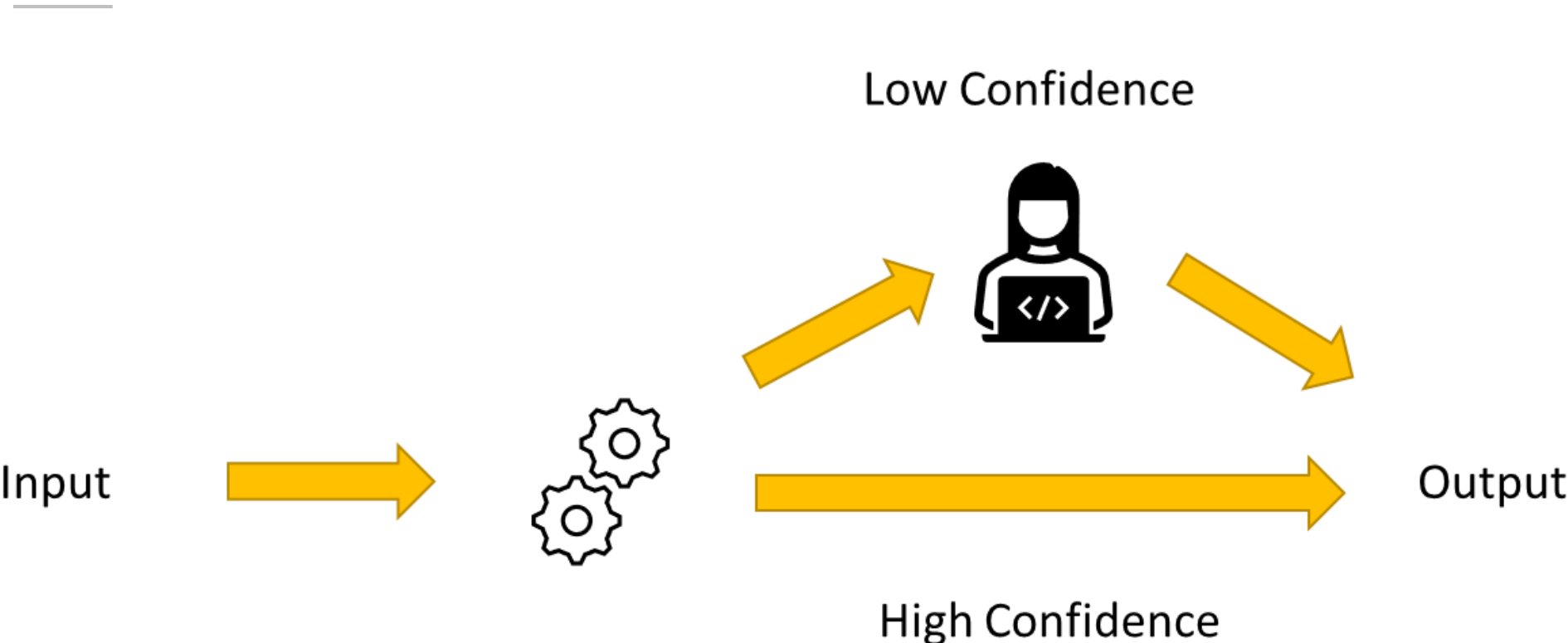

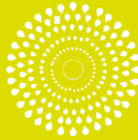

All in concert and perfectly attuned...

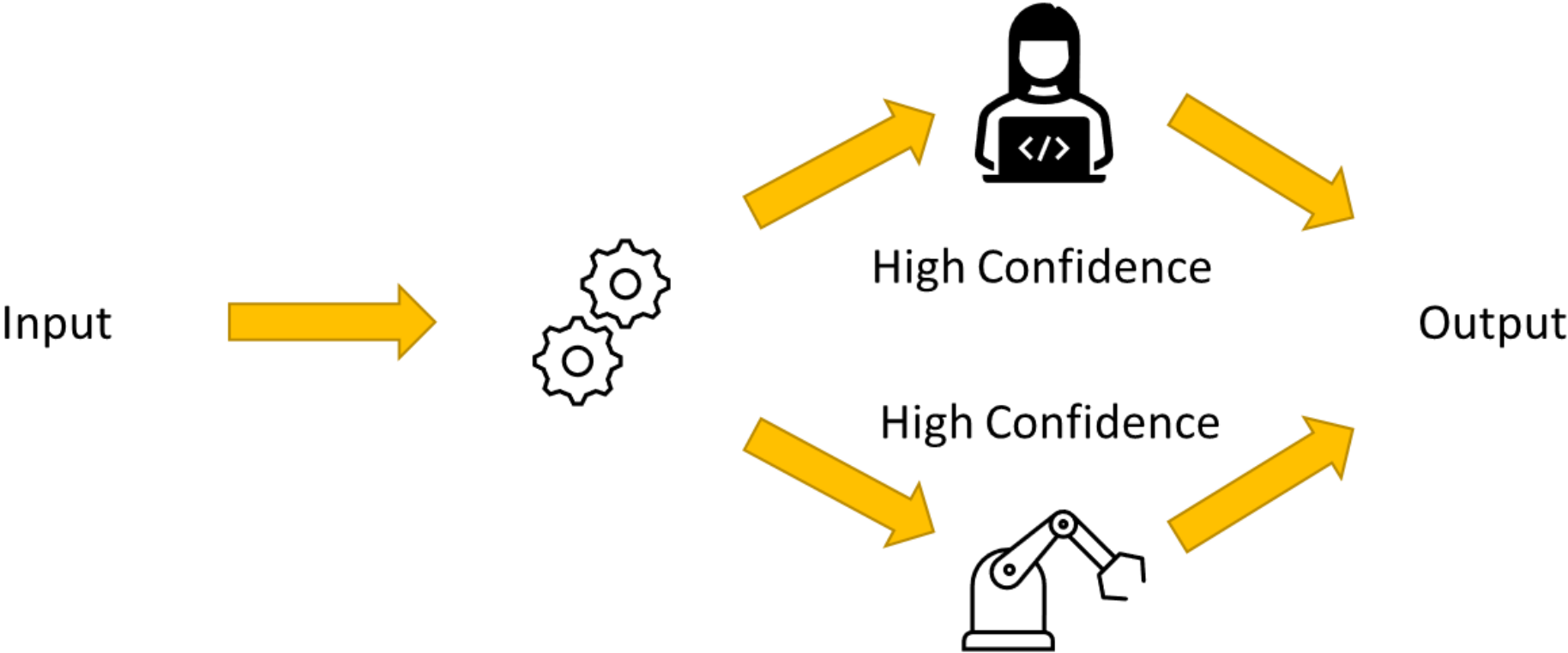

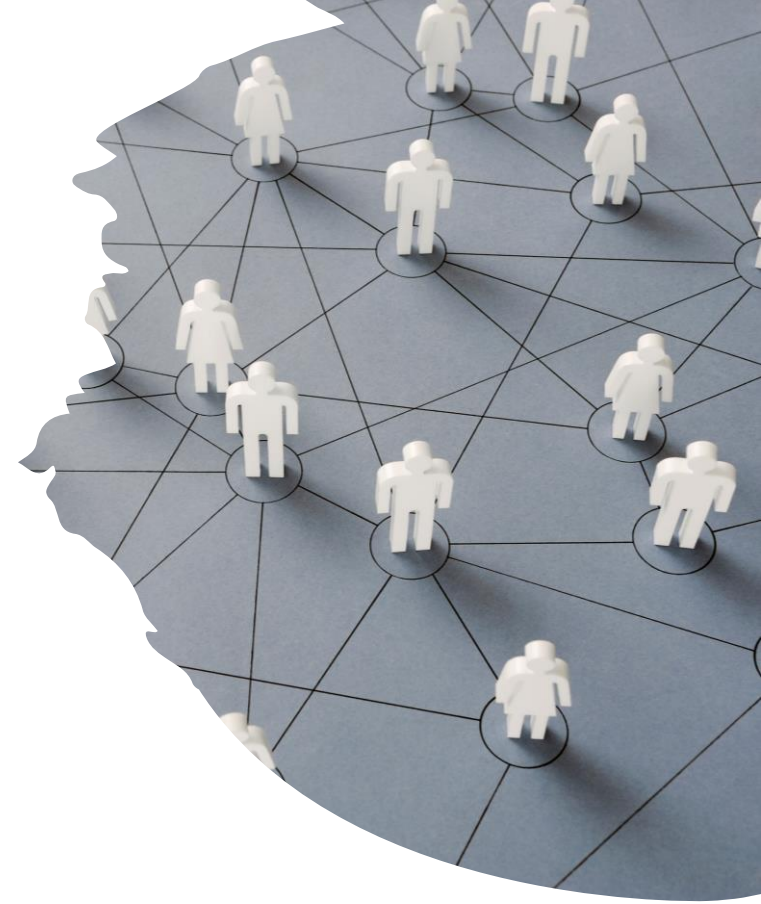
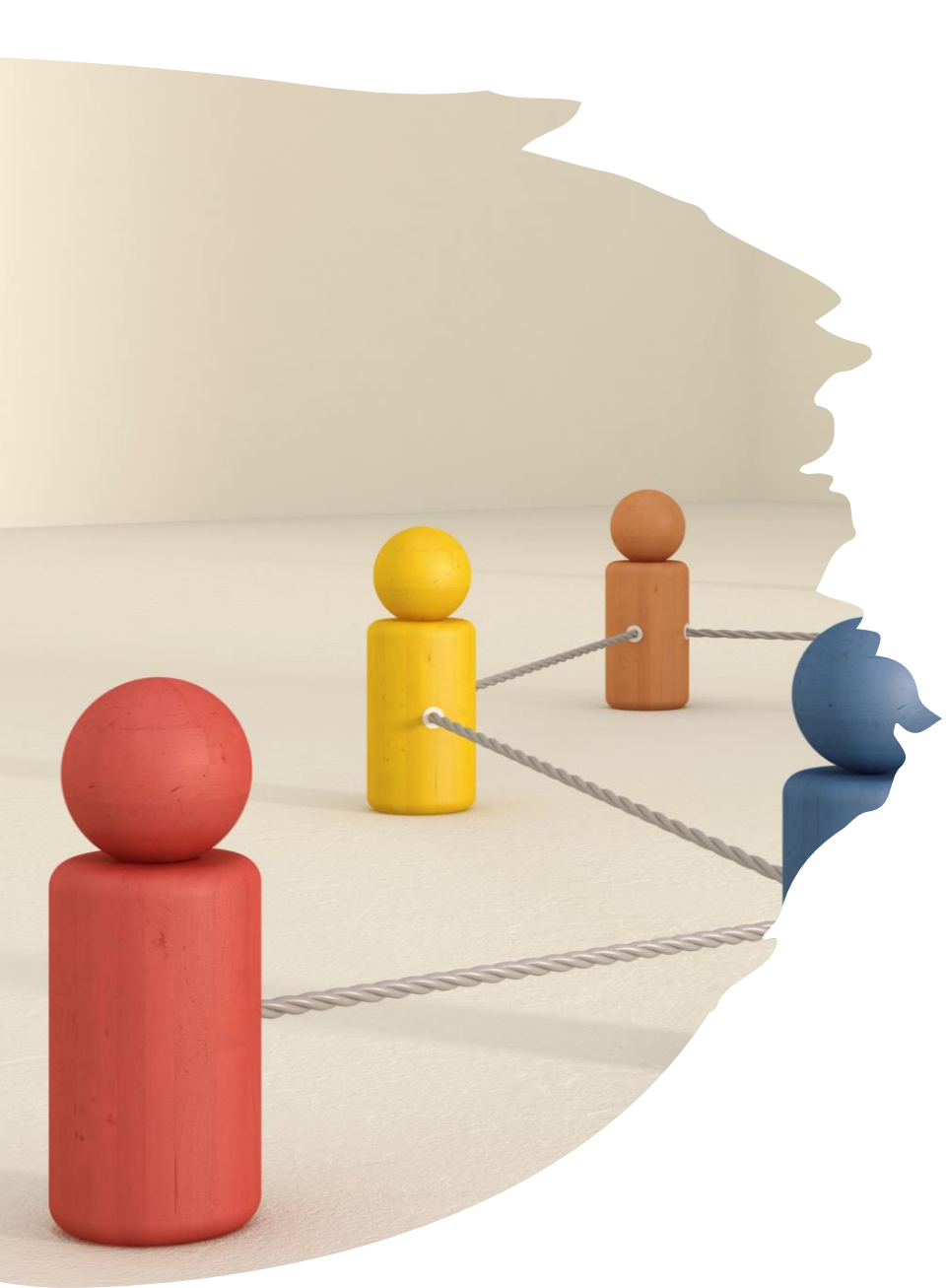

Enterprise wide
Individual decisions
Company decisions
Global Influences



Practical Example – Storage Tank Design & Manufacture

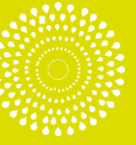

Storage Tank Design

- What would a storage tank look like if recycled material is used and the aim is to minimise (or have zero) waste in the manufacturing process?



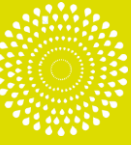

Investigating how a product evolves over generations

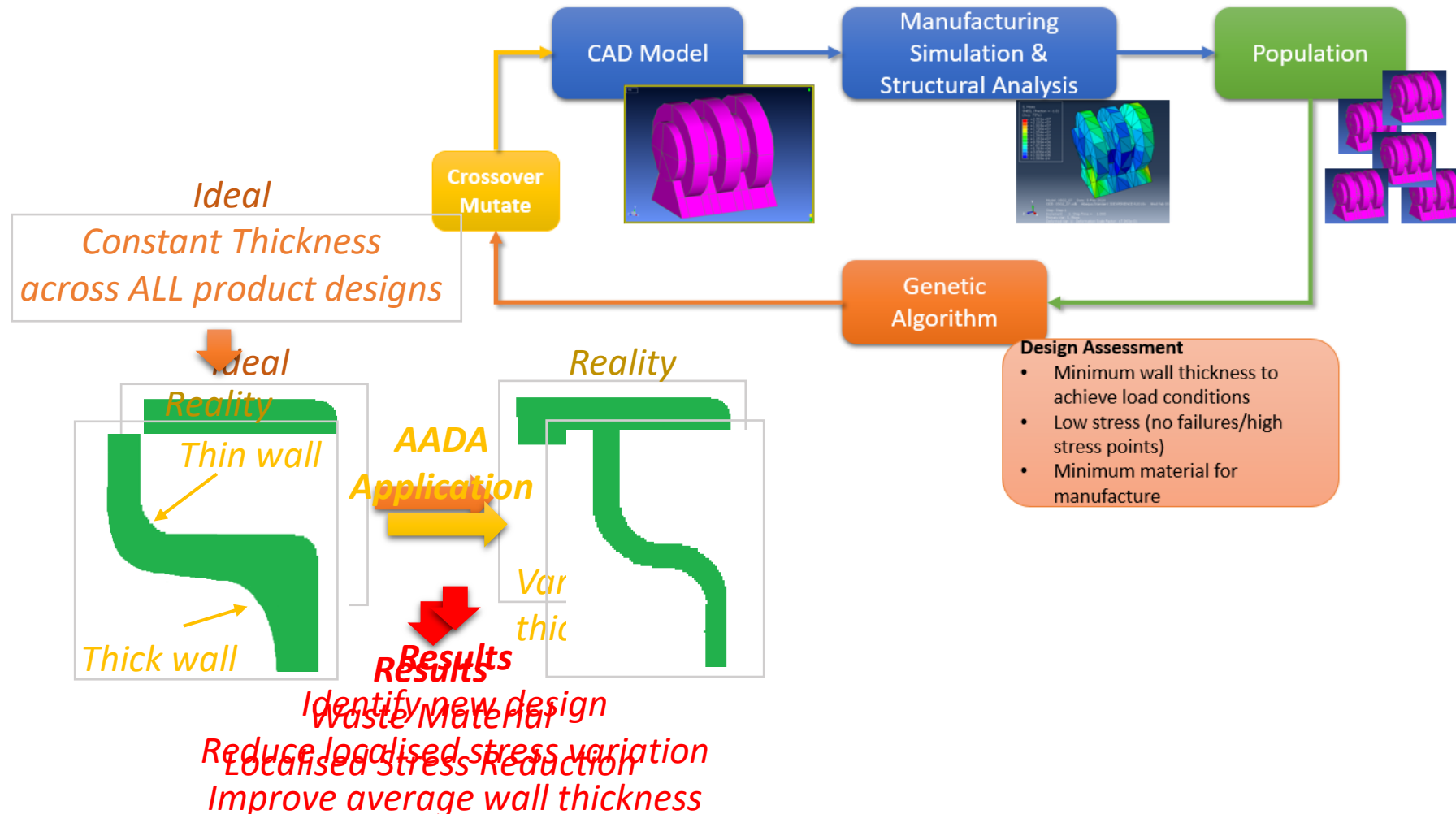

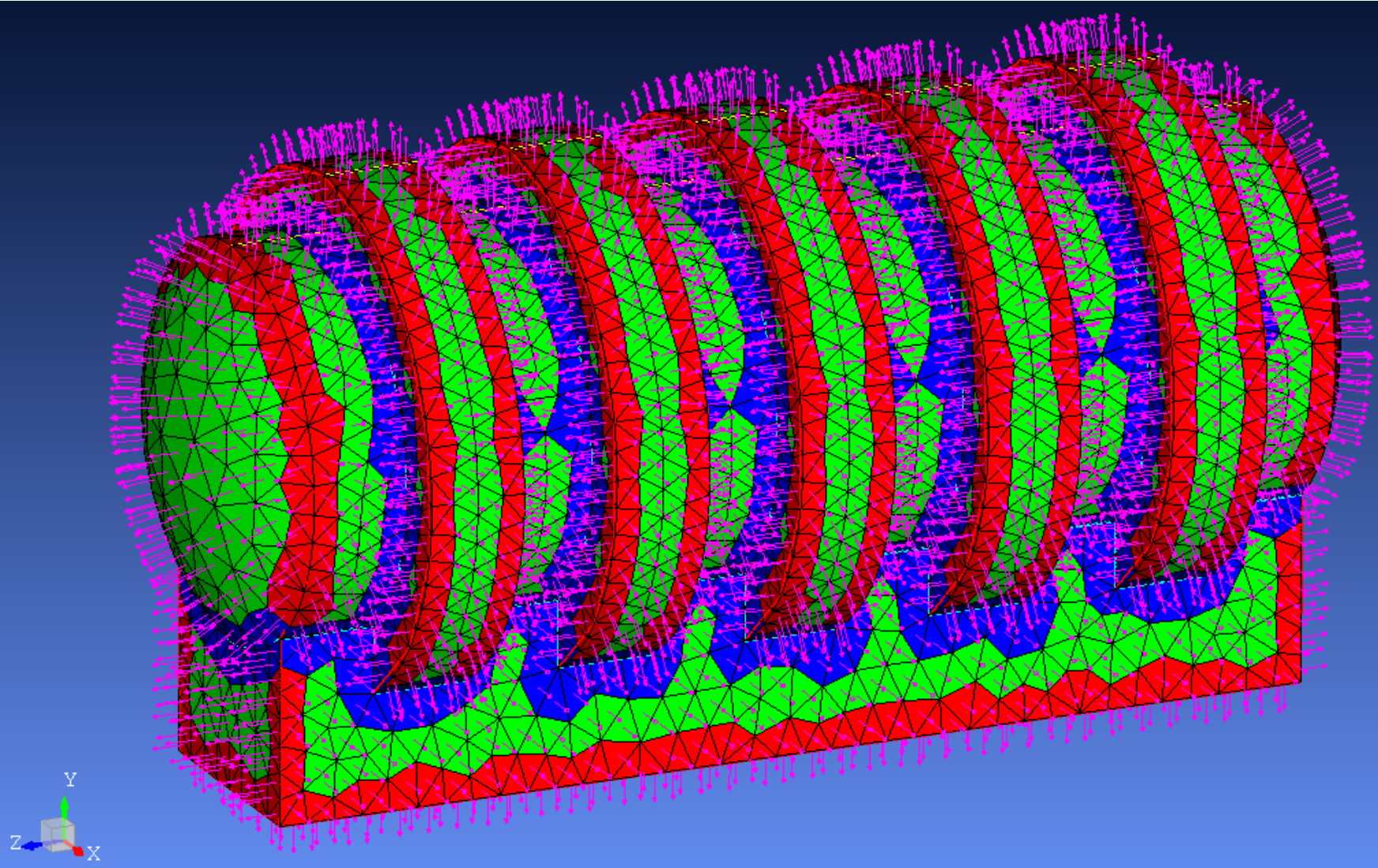
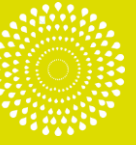

- Manufacturing information relating to wall thickness is fed back into the design models.
- Genes in this case align to key geometry design parameters.

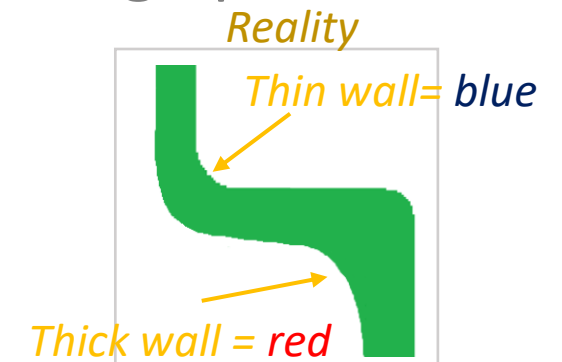

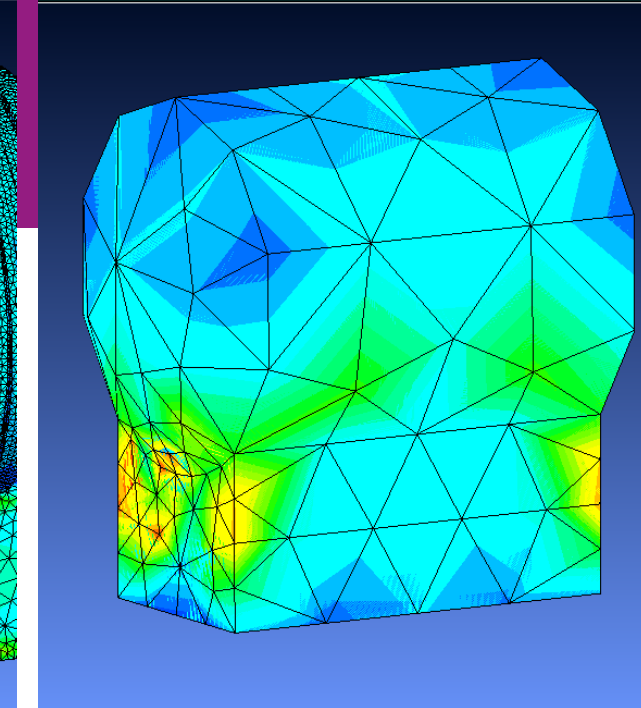
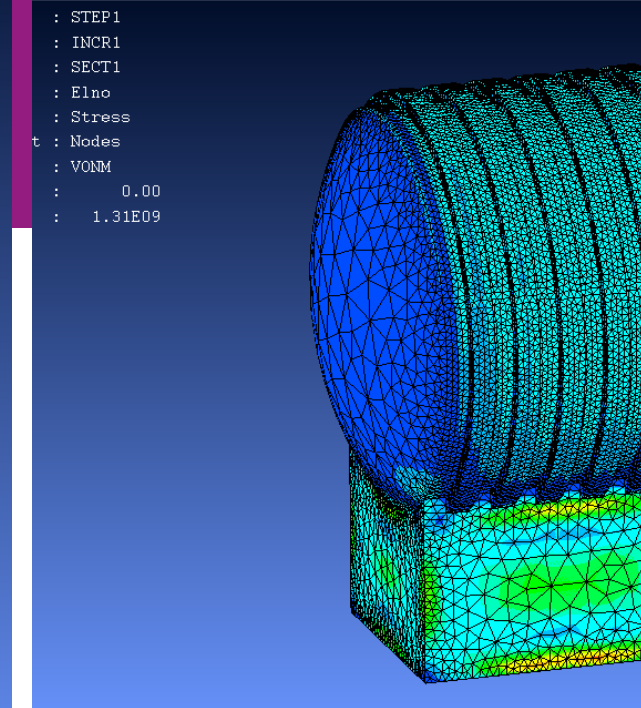
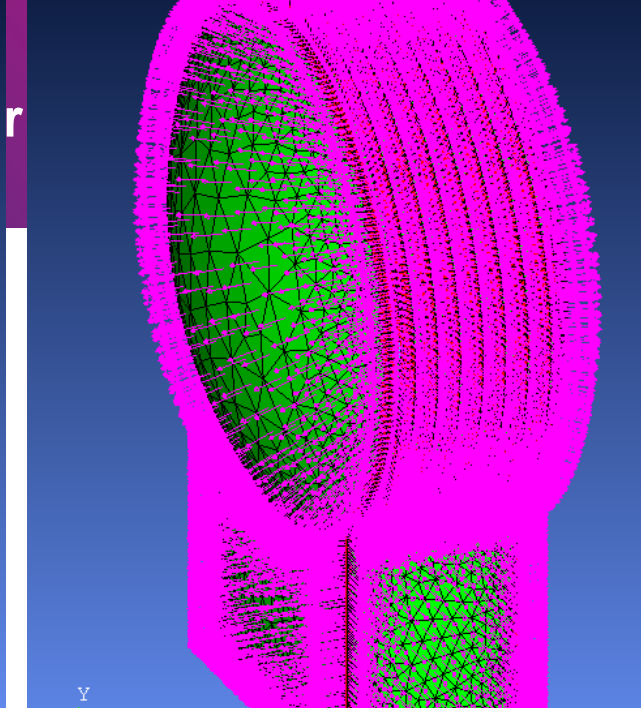
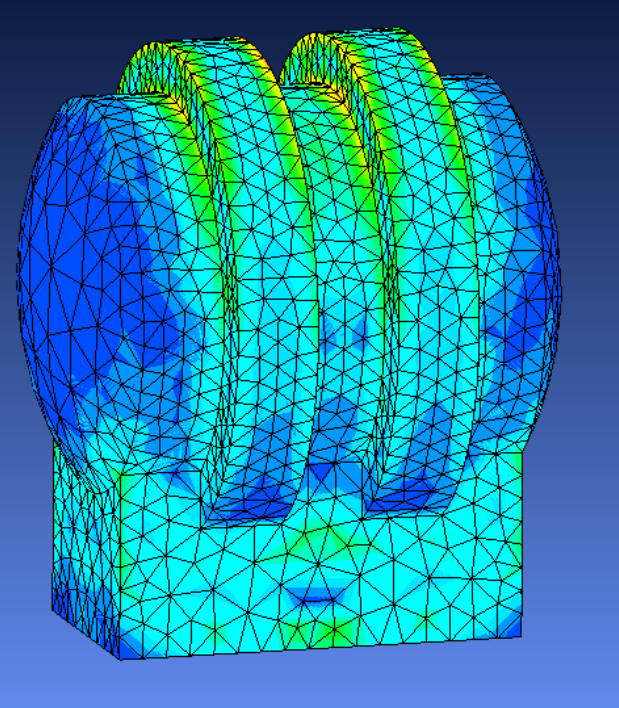

```
: STEP1  
: INCR1  
: SECT1  
: Eln0  
: Stress  
t : Nodes  
: VONM  
: 0.00  
: 1.31E09
```

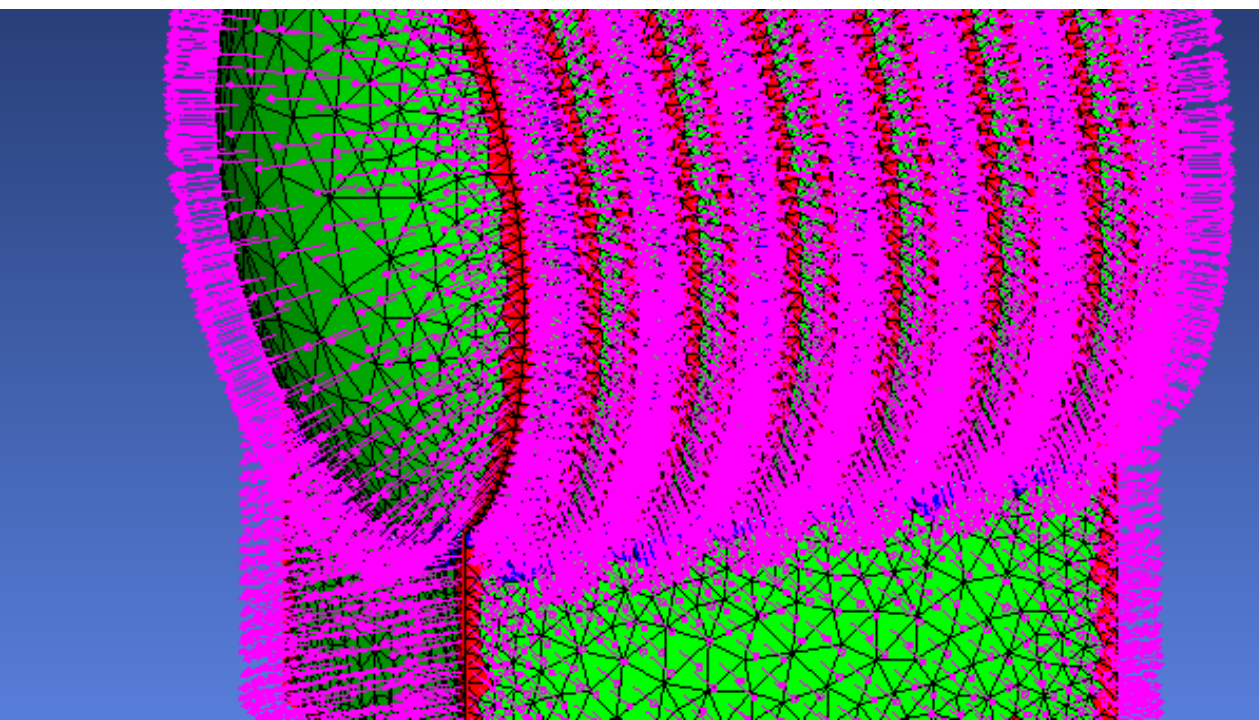

Topology, geometry, loading and supports are all changing as the tank 'organism' grows/develops.

```
: STEP1
ent : INCR1
n   : SECT5
rt  : Eln0
    : Stress
es at : Nodes
ated : VONM
    : 0.00
    : 4.96E08
```

Exploring a range of shapes and sizes over generations of material recycling

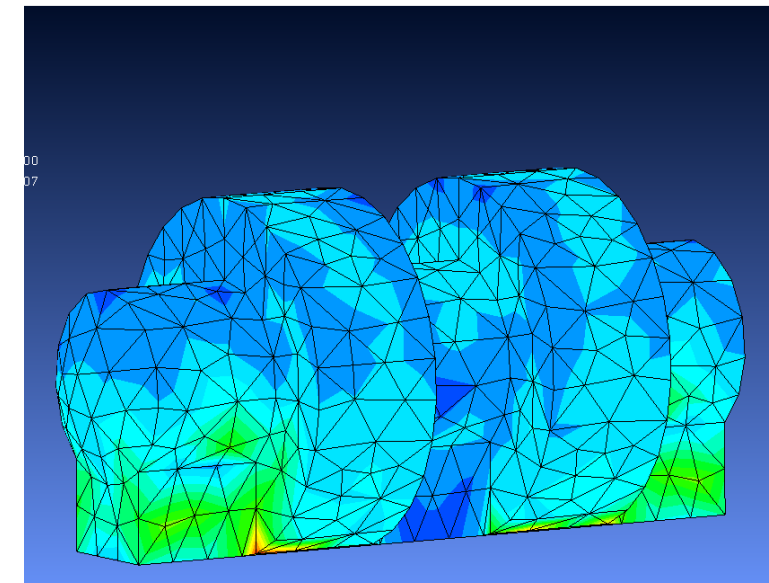
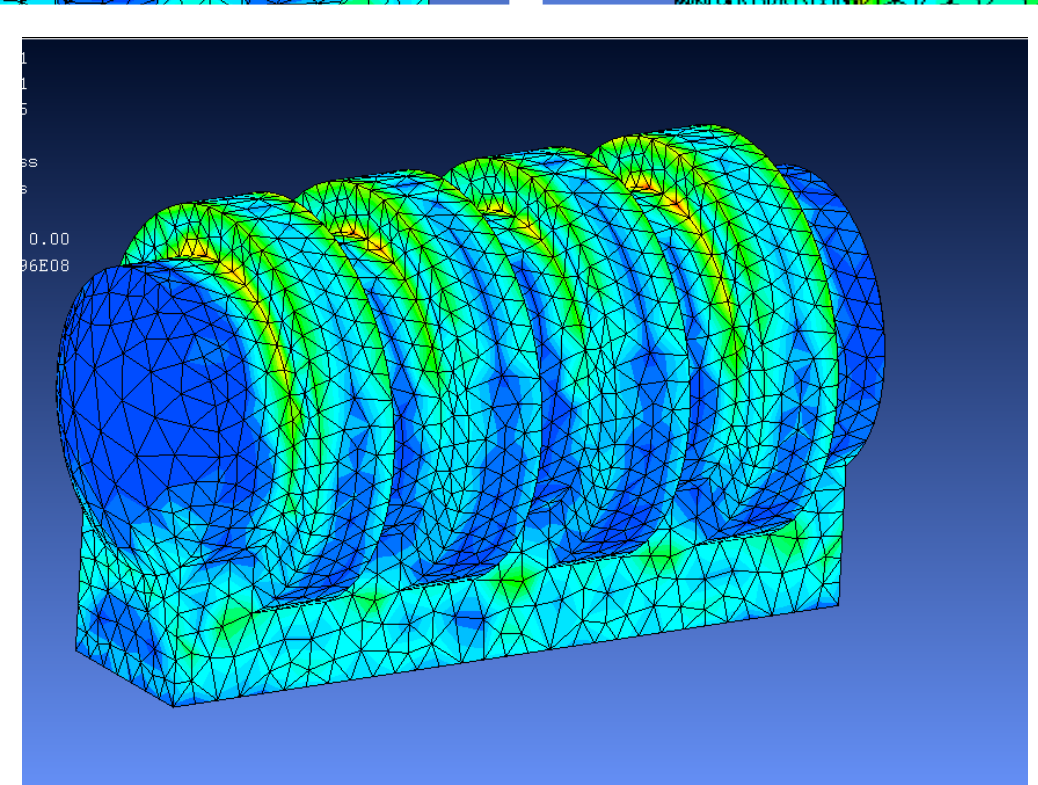
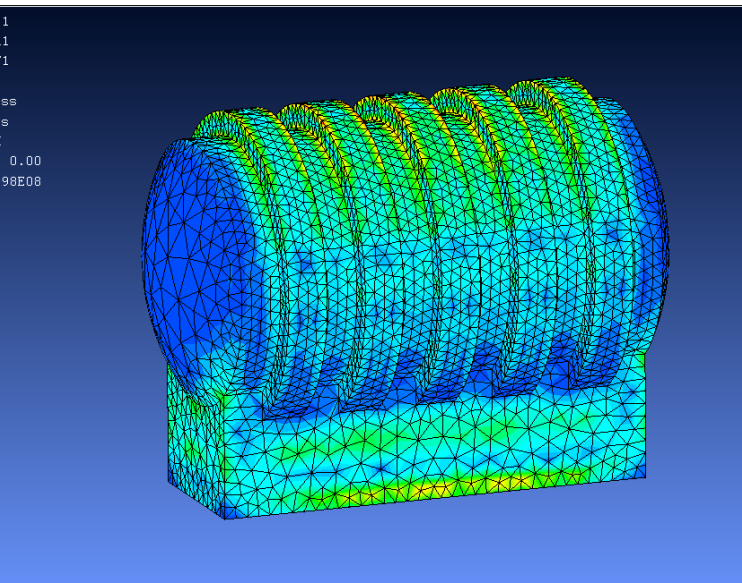
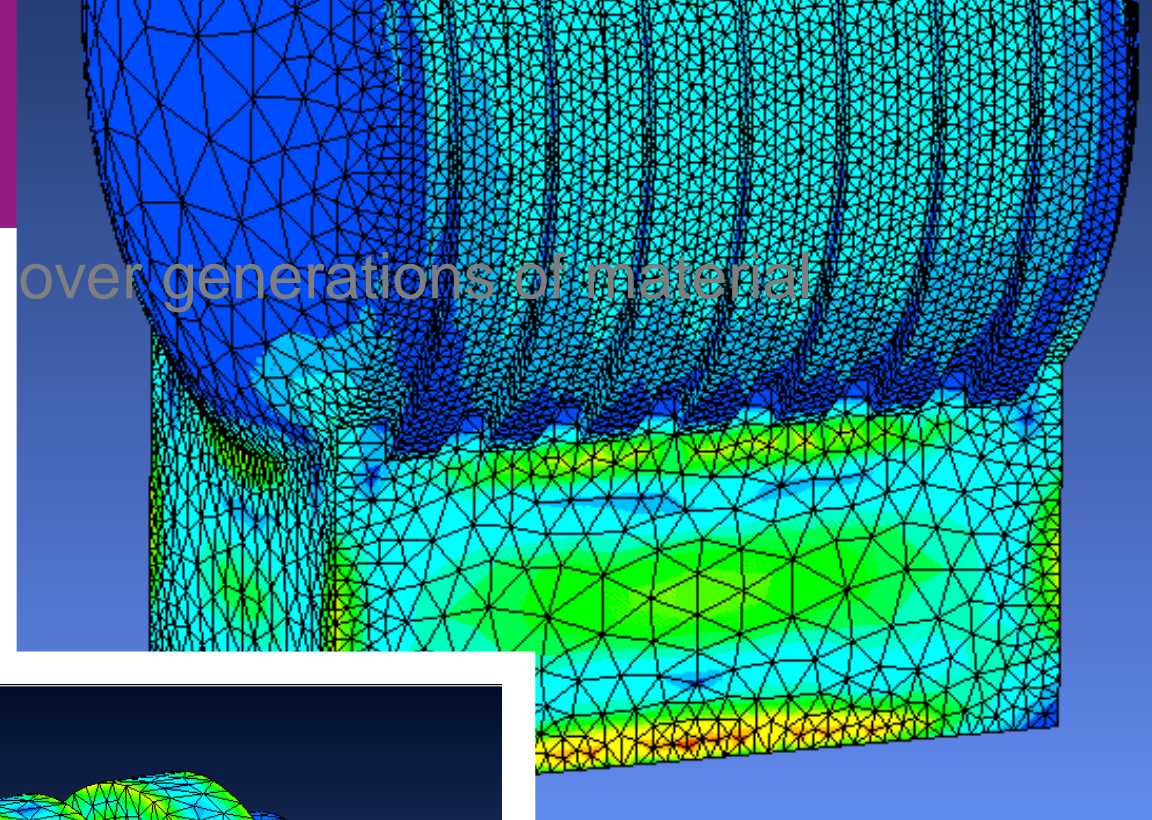
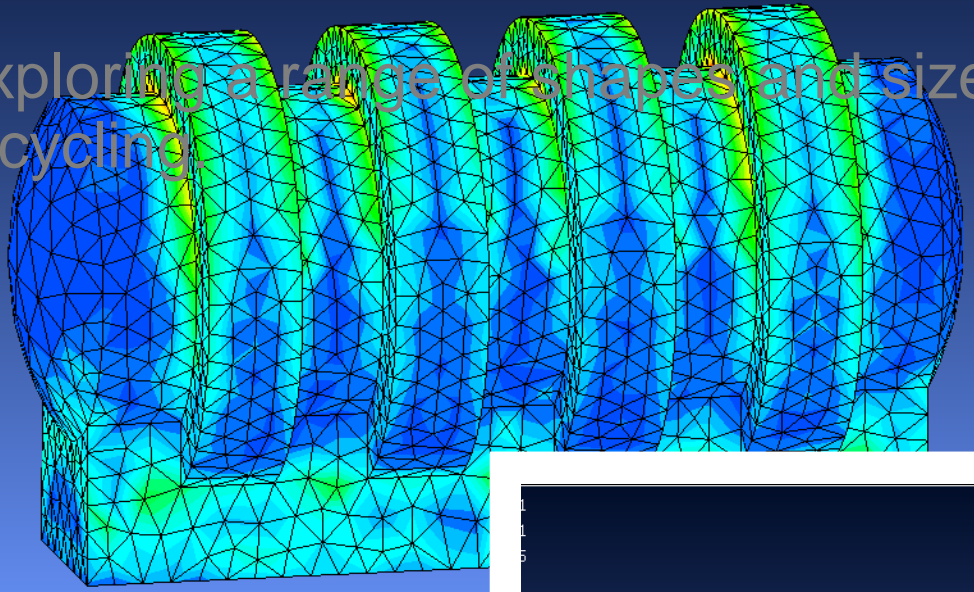

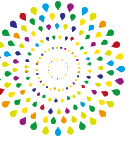

People Development

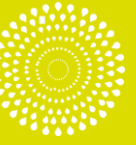

It's all about the Team

-
- 40 researchers involved
 - 10-20 practising engineers
 - International scholars providing advice
 - Outstanding companies

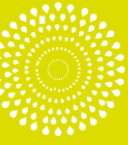

Special Development Programmes

- Outreach and Impact Team
- Investors in People Team
- Transition Zone training ethos
- Making Great Leaders
- Cross-Institutional Mentoring (Excel and Propel)
- Providing leadership opportunities (and shadowing) earlier in career.

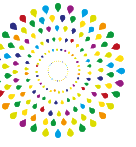

Thanks to...

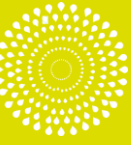

Thank You for Listening

— And remember.....

Imagination is the only weapon in the war against reality.”

— [Lewis Carroll, *Alice in Wonderland*](#)

